

# Wireless Power Transfer System and reduce abnormal noise for Electric Vehicles Using Block box testing Method in VANET

<sup>1</sup>Deepika.B, <sup>2</sup>Gopi.R, <sup>3</sup>Dr.A.Rajesh

<sup>1</sup>P.G Scholar, Dept of CSE, Dhanalakshmi Srinivasan Engineering College, India

<sup>2</sup>Research Scholar, St.Peter's University, Chennai,India

<sup>3</sup>HOD/CSE, C.Abdul Hakeem college of Engineering and Technology, Vellore, India

<sup>1</sup>deepi.b1992@gmail.com, <sup>2</sup>gopircse@gmail.com, <sup>3</sup>amrajesh73@gmail.com

**Abstract**— Vehicular ad-hoc networks (VANETs) to support real time communications among road-side units (RSUs) and highly mobile Electric Vehicle for collecting real-time vehicle mobility information or dispatching charging decisions. To improve the overall energy utilization for Electric vehicle and avoiding power system overloading. To addresses the range anxiety problem and reducing the overall travel cost using VANET Enhanced Smart Grid Technology. Effective black-box method for identification and diagnosis of abnormal noise sources of permanent magnet synchronous machines (PMSMs) for electric vehicles. Abnormal noise sources are identified and diagnosed by means of the black-box testing theory. Electric vehicles are charged on roadway by wireless power transfer technology. Also, electromagnetic force shielding for the electric vehicle is used to gain the 100-kW power with 80% power transfer efficiency under 26-cm air gap.

**Keywords**— Core structure, online electric vehicles (OLEVs), pickup, roadway-powered electric vehicles, wireless power transfer, permanent magnet synchronous machines (PMSM), sound quality.

## I. INTRODUCTION

The serious environmental pollution caused by internal combustion engines, together with the depletion of fossil fuels, has motivated global interest in eco-friendly energy. Notably, electric vehicle technology has been developed to reduce the use of fossil fuels in vehicles, which are the main fossil fuel consumers. As a result, hybrid electric vehicles that use both a combustion engine and an electric engine have already been widely commercialized. However, all-electric vehicles, such as plug-in electric vehicles and battery electric vehicles, are distributed narrowly at present owing to some battery-related drawbacks such as large size, heavy weight, high price, long charging time, and short driving range. These problems are not easily solved by current battery technology.

In an effort to address battery problems, the concept of roadway-powered electric vehicles has been proposed. With this system, the electric vehicle is charged on the road by wireless power charging, and the battery can hence be downsized and no waiting time for charging is needed. Much research on wireless power transfer for electric vehicles has been performed over the past few decades. In this project, a powering roadway track was constructed and was experimentally validated. Design methods of loosely coupled inductive power transfer systems have been proposed to overcome the large air gap for practical operation on roadways. To achieve high efficiency of power transfer, many techniques, including resonant inverters for wireless power transfer, efficient pickup modules, effective pickup tuning methods, and pickup voltage control method, have been proposed. Modeling methods can be classified into three categories [1]: 1) white-box modeling; 2) gray-box modeling; and 3) black box modeling.

The online electric vehicle (OLEV) center of the Korea Advanced Institute of Science and Technology has developed a high-efficiency roadway-powered electric vehicle system. The OLEV system achieved 100-kW output power with 80% power efficiency at a 26-cm air gap.

This paper describes the design and implementation of a wireless power transfer system for moving electric vehicles with examples involving the practical OLEV system. Section II explains the basic design and introduces the system operation. In Section III describes design of power transmitter & receiver part, and conclusions are provided in Section IV.

## II. METHOD

In the existing system, Environmental pollution caused by internal combustion engines, together with the depletion of fossil fuels, has motivated global interest in eco-friendly energy. Notably, electric vehicle technology has been developed to reduce the use of fossil fuels in vehicles, which are the main fossil fuel consumers. All-electric vehicles, such as plug-in electric vehicles and battery electric vehicles, are distributed narrowly at present owing to some battery-related.

But this system, the electric vehicle is charged on the road by wireless power charging, and the battery can hence be downsized and no waiting time for charging is needed. To achieve high output power and power transfer efficiency, an inverter, power line modules, pickup modules, rectifiers, and regulators were optimally designed. The OLEV system achieved 100-kW output power with 80% power efficiency at a 26-cm air gap. To know the vehicle to vehicle information. To identify the abnormal condition about the driver. To achieves high output power and power transfer efficiency. It provides the better performance.

### A. Basic Design

A wireless power transfer system uses inductive coupling. One of the most important factors that must be considered in designing an inductive coupling system is the target power of the system. Voltage and current ranges, usable devices, and operating frequency of the system depend on the target power. Because the wireless power transfer system for moving electric vehicles is a public service system that is installed in a road, the use of the resonance frequency must be permitted by the government. Generally, wireless power transfer systems for electric vehicles use 10–100-kHz frequency. In the OLEV system, the target power is 100 kW, and the resonance frequency is 20 kHz. To compensate the reactive power and increase the power efficiency, compensation capacitors are used in the OLEV system. These capacitors make the circuit resonate at the operating frequency and minimize the circuit impedance.

### B. System Operation

A wireless power transfer system consists of a power transmitter part and a power receiver part. The power transmitter part is composed of power supply, magnetic coil, Zigbee transmitter, temperature sensor, speed sensor and alcohol sensor. The power receiver part is composed of power supply, LEDs, Zigbee receivers, rectifiers, and regulators. ADC is used to generate power from induced voltage and current, the rectifiers convert ac power to dc, and the regulators control the output voltage, which is input to batteries and motors.

## III. DESIGN OF POWER TRANSMITTER & RECIEVER PART

### A. Power Supplies

Here introduces the operation of power supply circuits built using filters, rectifiers, and then voltage regulators. Starting with an ac voltage, a stable dc voltage is obtained by rectifying the ac voltage, then filtering to a dc level, and finally, regulating to obtain a desired fixed dc voltage. The regulation is usually obtained from an IC voltage regulator unit, which takes a dc voltage and provides a somewhat lower dc voltage, which remains the same even if the input dc voltage varies, or the output load connected to the dc voltage changes.

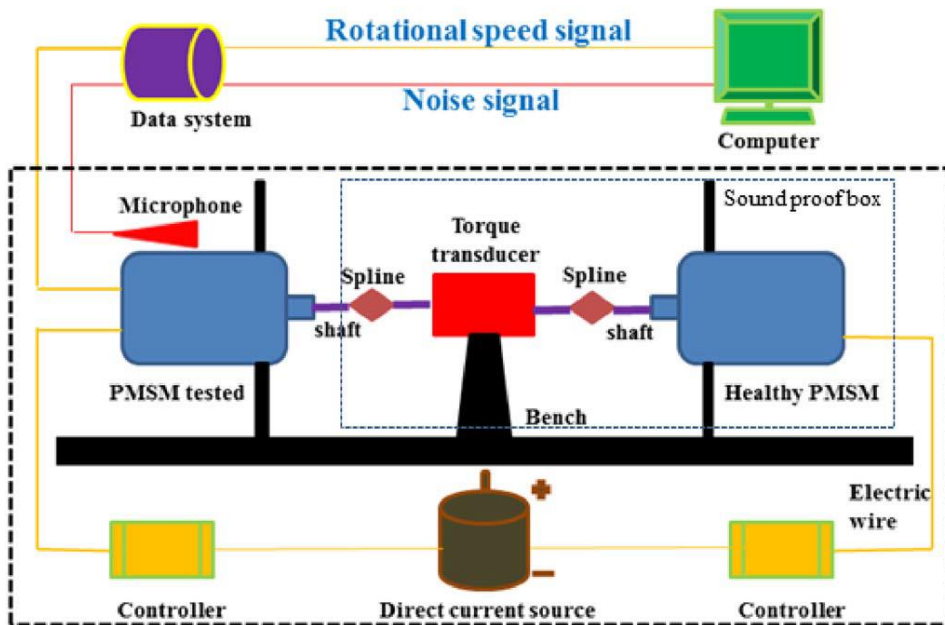

Owing to the confidentiality of the manufacturers of PMSMs, it is very difficult to obtain detailed internal parameters of the PMSM for vehicle system engineers. As a result, it is very difficult to investigate abnormal noise sources by means of white box modeling or gray-box modeling. In this chapter, a PMSM with 8 poles and 48 slots, of which the internal parameters were unknown, was tested, with the rotational speed varying from 0 to 6000 r/min. The experimental system is depicted. Considering the sampling method and according to the Nyquist law for sampling, the sampling frequency must be at least twice the maximum available frequency. The sampling frequency of the microphones was selected to be 48 000 Hz, which totally covered the human hearing frequency band. The SQ Lab III data system was used to collect data.

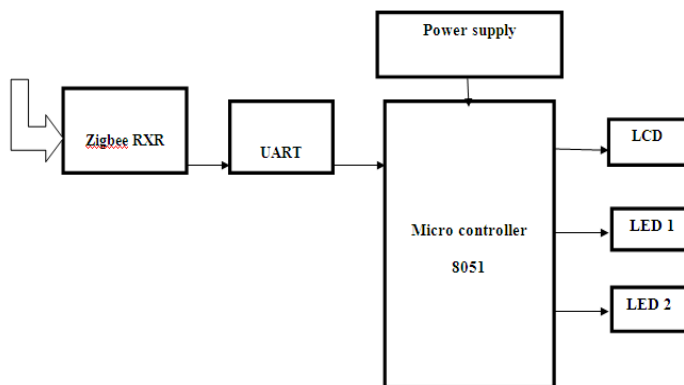

Figure 1: Transceiver

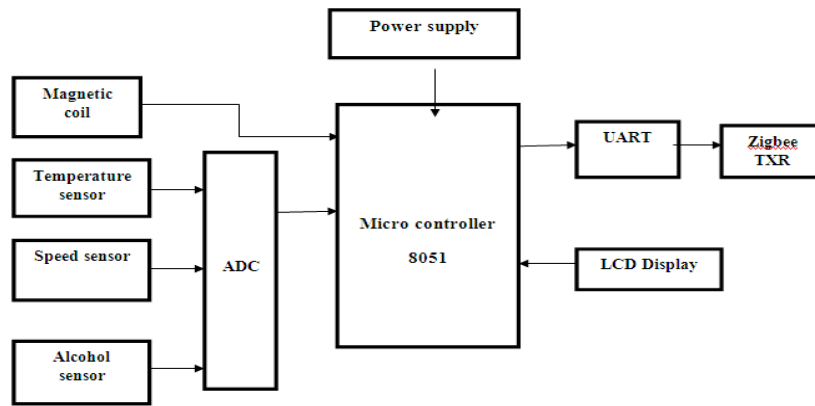

Figure 2: Receiver

#### IV. MICROCONTROLLER

A microcontroller (also microcontroller unit, MCU or  $\mu\text{C}$ ) is a small computer on a single integrated circuit consisting of a relatively simple CPU combined with support functions such as a crystal oscillator, timers, watchdog timer, serial and analog I/O etc. either Program memory in the form of NOR flash or OTP ROM is also often included on chip, as well as a typically small amount of RAM. Microcontrollers are designed for small or dedicated applications.

#### V. TEMPERATURE SENSOR

The LM35 series are precision integrated-circuit temperature sensors, whose output voltage is linearly proportional to the Celsius (Centigrade) temperature. The LM35 thus has an advantage over linear temperature sensors calibrated in  $^{\circ}\text{Kelvin}$ , as the user is not required to subtract a large constant voltage from its output to obtain convenient Centigrade scaling. The LM35 does not require any external calibration or trimming to provide typical accuracies of  $\pm 1/4^{\circ}\text{C}$  at room temperature and  $\pm 3/4^{\circ}\text{C}$  over a full  $-55$  to  $+150^{\circ}\text{C}$  temperature range. Low cost is assured by trimming and calibration at the wafer level. The LM35's low output impedance, linear output, and precise inherent calibration make interfacing to readout or control circuitry especially easy.

The LM35 is rated to operate over a  $-55^{\circ}$  to  $+150^{\circ}\text{C}$  temperature range, while the LM35C is rated for a  $-40^{\circ}$  to  $+110^{\circ}\text{C}$  range ( $-10^{\circ}$  with improved accuracy). The LM35 series is available packaged in hermetic TO-46 transistor packages, while the LM35C, LM35CA, and LM35D are also available in the plastic TO-92 transistor package. The LM35D is also available in an 8-lead surface mount small outline package and a plastic TO-220 package.



Figure 3: Temperature Sensor

Temperature Sensor is Calibrated directly in  $^{\circ}\text{Celsius}$  (Centigrade) and it is suitable for remote applications. Low cost due to wafer-level trimming and it's operates from 4 to 30 volts. Low self-heating compare with other sensors.

#### VI. GAS SENSOR

A gas detector is a device which detects the presence of various gases within an area, usually as part of a safety system. This type of equipment is used to detect a gas leak and interface with a control system so a process can be automatically shut down. A gas detector can also sound an alarm to operators in the area where the leak is occurring, giving them the opportunity to

leave the area. This type of device is important because there are many gases that can be harmful to organic life, such as humans or animals.



Figure 4: Gas Sensor

This sensor used to indicate the high sensitivity to LPG, natural gas, town gas and also small sensitivity to alcohol, smoke. Gas sensor gives fast response to the user when the emergency situations. So this sensor is used in gas leakage detecting equipments in family and industry, are suitable for detecting of LPG, natural gas , town gas, avoid the noise of alcohol and cooking fumes and cigarette smoke.

### VII. ADC

The ADC0808, ADC0809 data acquisition component is a monolithic CMOS device with an 8-bit analog-to-digital converter, 8-channel multiplexer and microprocessor compatible control logic. The 8-bit A/D converter uses successive approximation as the conversion technique. The converter features a high impedance chopper stabilized comparator, a 256R voltage divider with analog switch tree and a successive approximation register. The 8-channel multiplexer can directly access any of 8-single-ended analog signals.

The device eliminates the need for external zero and full-scale adjustments. Easy interfacing to microprocessors is provided by the latched and decoded multiplexer address inputs and latched TTL TRI-STATE® outputs. The design of the ADC0808, ADC0809 has been optimized by incorporating the most desirable aspects of several A/D conversion techniques. The ADC0808, ADC0809 offers high speed, high accuracy, minimal temperature dependence, excellent long-term accuracy and repeatability, and consumes minimal power. These features make this device ideally suited to applications from process and machine control to consumer and automotive applications. For 16-channel multiplexer with common output (sample/hold port) see ADC0816 data sheet. (See AN-247 for more information.)

ADC is used in the transmitter circuit because it is used to easy interface to all microprocessors and also it operates ratiometrically or with 5 VDC or analog spanIt is provides the power supply and using ADC provides outputs meet TTL voltage level specifications

### VIII. ZIGBEE

ZigBee is a specification for a suite of high level communication protocols using small, low-power digital radios based on the IEEE 802.15.4-2003 standard for wireless personal area networks (WPANs), such as wireless headphones connecting with cell phones via short-range radio. The technology defined by the ZigBee specification is intended to be simpler and less expensive than other WPANs, such as Bluetooth. ZigBee is targeted at radio-frequency (RF) applications that require a low data rate, long battery life, and secure networking.



Figure 5: ZigBee

ZigBee is the IEEE Std. 802.15.4™ Compliant RF Transceiver and it is Proprietary Wireless Networking Protocols. It is having the Integrated Crystal, Internal Voltage Regulator and Matching Circuitry, PCB Antenna. Why we use ZigBee means it is Easy Integration into Final Product, Minimize Product Development, and Quicker Time to Market.

#### IX. LCD DISPLAY

A liquid crystal display (LCD) is a thin, flat panel used for electronically displaying information such as text, images, and moving pictures. Its uses include monitors for computers, televisions, instrument panels, and other devices ranging from aircraft cockpit displays, to every-day consumer devices such as video players, gaming devices, clocks, watches, calculators, and telephones. Among its major features are its lightweight construction, its portability, and its ability to be produced in much larger screen sizes than are practical for the construction of cathode ray tube (CRT) display technology. Its low electrical power consumption enables it to be used in battery-powered electronic equipment.

#### X. MAGNETIC COIL

An Electromagnetic coil is an electrical conductor such as a wire in the shape of a coil, spiral or helix. Electromagnetic coils are used in electrical engineering, in applications where electric currents interact with magnetic fields, in devices such as inductors, electromagnets, transformers, and sensor coils. Either an electric current is passed through the wire of the coil to generate a magnetic field, or conversely an external time-varying magnetic field through the interior of the coil generates an EMF (voltage) in the conductor.

A current through any conductor creates a circular magnetic field around the conductor due to Ampere's law. The advantage of using a coil shape is that it increases the strength of magnetic field produced by a given current. The magnetic fields generated by the separate turns of wire all pass through the center of the coil and add (superpose) to produce a strong field there. The more turns of wire, the stronger the field produced. Conversely, a changing external magnetic flux induces a voltage in a conductor such as a wire, due to Faraday's law of induction. The induced voltage can be increased by winding the wire into a coil, because the field lines intersect the circuit multiple times.

The direction of the magnetic field produced by a coil can be determined by the right hand grip rule. If the fingers of the right hand are wrapped around the magnetic core of a coil in the direction of conventional current through the wire, the thumb will point in the direction the magnetic field lines pass through the coil.

Many electromagnetic coils have a magnetic core, a piece of ferromagnetic material like iron in the center to increase the magnetic field. The current through the coil magnetizes the iron, and the field of the magnetized material adds to the field produced by the wire. This is called a ferromagnetic-core or iron-core coil. A ferromagnetic core can increase the magnetic field of a coil by hundreds or thousands of times over what it would be without the core.

#### XI. CONCLUSION

A VANET Enhanced smart grid have some functionalities of real time vehicle, the information are collected through vehicular network. Then, a Wireless Power Transfer System for Electric Vehicles Using Magnetic Resonance in VANE strategy was proposed to maximize the overall charging energy minus travel cost power system overloading. This paper has presented the design and implementation of a wireless power transfer system for moving electric vehicles. To achieve high output power and power transfer efficiency, transmitter and receiver modules were optimally designed. In the end, abnormal noise sources are properly identified and diagnosed by analyzing the rotational speed signal and the noise signal. The black box modeling does not need internal parameters of PMSMs. Here using different sensors such as Gas sensors, Temperature sensors for user benefit oriented when meet the emergency situations. For transmit and receiving purpose using zigbee component.

#### References

- [1] Roadway powered electric vehicle project track construction and test-ing program phase 3D, Partners Advanced Transit Highways (PATH), Berkeley, CA, USA, Res. Rep. [Online]. Available: <http://www.path.berkeley.edu>
- [2] O. H. Stielau and G. A. Covic, "Design of loosely coupled induc-tive power transfer systems," in *Proc. Int. Conf. Power Syst. Technol.*, Dec. 2000, vol. 1, pp. 85–90.
- [3] C. J. Chen, T. H. Chu, C. L. Lin, and Z. C. Jou, "A study of loosely coupled coils for wireless power transfer," *IEEE Trans. Circuits Syst.*, vol. 57, no. 71,

- pp. 536–540, Jul. 2010.
- [4] C. Wang, G. A. Covic, and O. H. Stielau, “Power transfer capability and bifurcation phenomena of loosely coupled inductive power transfer systems,” *IEEE Trans. Ind. Electron.*, vol. 51, no. 1, pp. 148–157, Feb. 2004.
- [5] M. Budhia, G. A. Covic, and J. T. Boys, “Design and optimization of circular magnetic structures for lumped inductive power transfer systems,” *IEEE Trans. Power Electron.*, vol. 26, no. 11, pp. 3096–3108, Nov. 2011.
- [6] C. Wang, O. H. Stielau, and G. A. Covic, “Design considerations for a contactless electric vehicle battery charger,” *IEEE Trans. Ind. Electron.*, vol. 52, no. 5, pp. 1308–1314, Oct. 2005.
- [7] J. Sallan, J. L. Villa, A. Llombart, and J. F. Sanz, “Optimal design of ICPT systems applied to electric vehicle battery charge,” *IEEE Trans. Ind. Electron.*, vol. 56, no. 6, pp. 2140–2149, Jun. 2009.
- [8] T. Imura and Y. Hory, “Maximizing air gap and efficiency of magnetic resonant coupling for wireless power transfer using equivalent circuit and Neumann formula,” *IEEE Trans. Ind. Electron.*, vol. 58, no. 10, pp. 4746–4752, Oct. 2011.
- [9] H. Abe, H. Sakamoto, and K. Harada, “A noncontact charger using resonant converter with parallel capacitor of the secondary coil,” in *Proc. IEEE APEC*, Feb. 1998, vol. 1, pp. 136–141.
- [10] C. Wang, G. A. Covic, and O. H. Stielau, “Investigating an LCL load resonant inverter for inductive power transfer applications,” *IEEE Trans. Ind. Electron.*, vol. 19, no. 4, pp. 995–1002, Jul. 2004.
- [11] J. Meins, G. Buhler, R. Czainski, and F. Turki, “Contactless inductive power supply,” in *Proc. 19th Int. Conf. Magn. Levitated Syst. Linear Drives*, Sep. 2006, pp. 1–9.
- [12] M. Borage, S. Tiwari, and S. Kotaiah, “Analysis and design of an LCL-T resonant converter as a constant-current power supply,” *IEEE Trans. Ind. Electron.*, vol. 52, no. 6, pp. 1547–1554, Dec. 2005.
- [13] S. Raabe, G. A. J. Elliott, G. A. Covic, and J. T. Boys, “A quadrature pickup for inductive power transfer systems,” in *Proc. IEEE Conf. Ind. Electron. Appl.*, May 2007, pp. 68–73.
- [14] M. L. G. Kissin, G. A. Covic, and J. T. Boys, “Steady-state flat-pickup loading effects in polyphase inductive power transfer systems,” *IEEE Trans. Ind. Electron.*, vol. 58, no. 6, pp. 2274–2282, Jun. 2011.
- [15] G. A. J. Elliott, S. Raabe, G. A. Covic, and J. T. Boys, “Multi-phase pick-ups for large lateral tolerance contactless power transfer systems,” *IEEE Trans. Ind. Electron.*, vol. 57, no. 5, pp. 1590–1598, May 2010.
- [16] J. James, J. T. Boys, and G. A. Covic, “A variable inductor based tuning method for ICPT pickups,” in *Proc. 7th Int. Conf. Power Eng.*, Dec. 2005, vol. 2, pp. 1142–1146.
- [17] M. Zaheer, N. Patel, and A. P. Hu, “Parallel tuned contactless power pickup using saturable core reactor,” in *Proc. Int. Conf. Sustain. Energy Technol.*, Dec. 2010, pp. 1–6.
- [18] G. A. Covic, J. T. Boys, A. M. W. Tam, and J. C. H. Peng, “Self tuning pick-ups for inductive power transfer,” in *Proc. IEEE Power Electron. Spec. Conf.*, Jun. 2008, pp. 3489–3494.
- [19] H. H. Wu, J. T. Boys, and G. A. Covic, “An AC processing pickup for IPT systems,” *IEEE Trans. Power Electron.*, vol. 25, no. 5, pp. 1275–1284, May 2010.
- [20] H. H. Wu, G. A. Covic, and J. T. Boys, “A series-tuned inductive-power-transfer pickup with a controllable AC-voltage output,” *IEEE Trans. Power Electron.*, vol. 26, no. 1, pp. 98–109, Jan. 2011.
- [21] J. Shin, B. Song, S. Lee, S. Shin, Y. Kim, G. Jung, and S. Jeon, “Contact-less power transfer systems for on-line electric vehicle (OLEV),” in *Proc. IEEE Int. Electric Veh. Conf.*, Mar. 2012, pp. 1–4.
- [22] S. W. Lee, J. Huh, C. B. Park, N. S. Choi, G. H. Cho, and C. T. Rim, “On-line electric vehicle using inductive power transfer system,” in *Proc. IEEE Energy Convers. Congr. Expo.*, Sep. 2010, pp. 1598–1601.
- [23] G. Jung, B. Song, S. Shin, S. Lee, J. Shin, Y. Kim, S. Jeon, and D. Cho, “High efficient inductive power supply and pickup system for on-line electric bus,” in *Proc. IEEE Int. Elect. Veh. Conf.*, Mar. 2012, pp. 1–5.
- [24] S. Shin, J. Shin, Y. Kim, S. Lee, B. Song, G. Jung, and S. Jeon, “Hybrid inverter segmentation control for online electric vehicle,” in *Proc. IEEE Int. Elect. Veh. Conf.*, Mar. 2012, pp. 1–6.
- [25] J. Huh, S. W. Lee, C. B. Park, G. H. Cho, and C. T. Rim, “High performance inductive power transfer system with narrow rail width for on-line electric vehicles,” in *Proc. IEEE Energy Convers. Congr. Expo.*, Sep. 2010, pp. 647–651.
- [26] Y. Kim, Y. Son, S. Shin, J. Shin, B. Song, S. Lee, G. Jung, and S. Jeon, “Design of a regulator for multi-pick-up systems through using current offsets,” in *Proc. IEEE Int. Elect. Veh. Conf.*, Mar. 2012, pp. 1–6.
- [27] S. Ahn, J. Park, T. Song, H. Lee, J. Byun, D. Kang, C. Choi, E. Kim, J. Ryu, M. Kim, Y. Cha, Y. Chun, C. Rim, J. Yim, D. Cho, and J. Kim, “Low frequency electromagnetic field reduction techniques for the on-line electric vehicle (OLEV),” in *Proc. IEEE Int. Symp. Electromagn. Compat.*, Jul. 2010, pp. 625–630.
- [28] C. Kim, D. Seo, J. You, J. Park, and B. H. Cho, “Design of a contactless battery charger for cellular phone,” *IEEE Trans. Ind. Electron.*, vol. 48, no. 6, pp. 1238–1247, Dec. 2001.
- [29] A. P. Sample, D. A. Meyer, and J. R. Smith, “Analysis, experimental results, and range adaptation of magnetically coupled resonators for wire-less power transfer,” *IEEE Trans. Ind. Electron.*, vol. 58, no. 2, pp. 544–554, Feb. 2011.
- [30] “Guidelines for limiting exposure to time-varying electric, magnetic, and electromagnetic fields (up to 300 GHz),” *Health Phys.*, vol. 74, no. 4, pp. 494–522, Apr. 1998.