

# Poisonous gas detection using self localized robot

Aswini.P

Final year m-tech student, Digital Electronics, Malabar Institute of Technology  
Anjarakkandy, Kerala, India  
aswinip91@gmail.com

**Abstract**— Underground mines and tunnels are an inhospitable place to work due to the presence of poisonous gases. Gas poisoning and unpredictable environmental changes are major hazards by which thousands of people die every year. This robotic vehicle is a self localized robot that can detect the presence of toxic gases and environmental conditions. Set of sensors in the robotic vehicle continuously monitor the toxic gases and environmental conditions, and the real time data is send to the user through an application. The self localized robot does not require external reference facilities, expensive hardware, careful tuning or strict calibration, and is capable of operating under various indoor and outdoor environments. It identifies the local relative movement through GPS augmentation.

**Keywords**— localization; robot; sensor; GPS; Wi-Fi; Android;

## I. INTRODUCTION

Poisonous gas detection using robotic vehicles have great potential in situations that are either uncomfortable for humans. For example, a robot becomes a part of industrial operations, senior citizen's life, a tour guide for exhibition hall. The robot is kept as small as possible to allow access through narrow passage ways.

To fulfill these missions, the robotic vehicle often has to obtain its accurate localization in real time. Many of the localization system require external facilities and human involvement such as manual calibration or management to obtain positioning. This self contained positioning system integrated into the robotic vehicle does not require any external facilities. Meanwhile, the cost is expected to be as low as possible. There exist various localization schemes for ground robotic vehicles. These techniques normally utilize inertial sensors, radio signals, or visual processing.

## II. PREVIOUS WORK

One scheme is radio based positioning requires proper calibration. In this positioning system requires a friendly environment and a set of external devices to generate and receive radio signals. This technology requires external devices; as the reference nodes should have known positions. The accuracy of these positioning scheme is strongly depends on the calibration of the reference devices and the target nodes. Also this scheme also requires a friendly radio environment and also it's costly in terms of additional hardware, strict calibration. It's vulnerable to interference from other signals that affecting the accuracy of this positioning system.

Another scheme is the use of visual processing, relies heavily on recognition of objects or shapes, and has restricted spatial and visual requirements. Performance is strongly depends on the robot operating environment and localization suffer frequent failure. Next scheme is set of inertial sensors are part of robot design. These inertial sensors are used to detect the movement. However, previous methods of maintaining their accuracy resulted in high cost and calibration difficulty.

## III. PROPOSED SYSTEM

This paper say's that this robotic vehicle uses GPS augmentation to detect global positioning and correcting the drifting errors if necessary. This self localized robot can be applied to both indoor and outdoor environments. The information analyzed into the robotic vehicle. This analyzed information sent to the receiver section through Wi-Fi communication. In the receiver side, these received data's and there levels are displayed through an android application using mobile. Heart of this robotic vehicle is an ARM 7 micro controller.

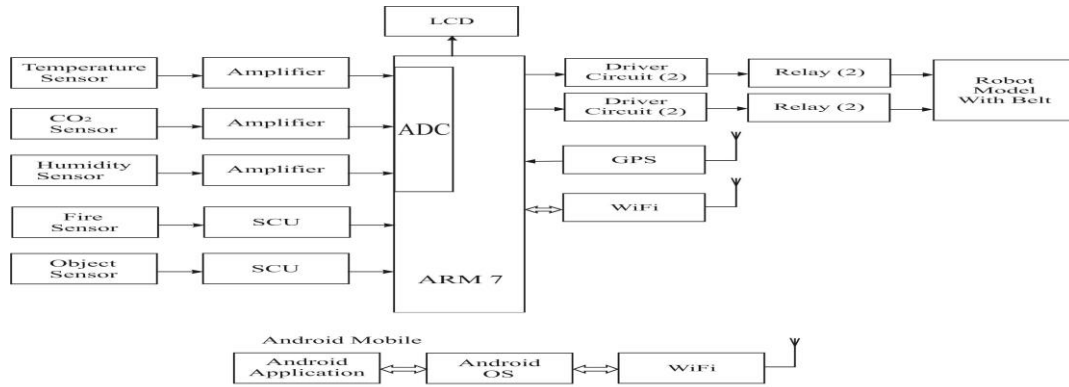

Figure 1: block diagram of proposed system

A. Proposed system

Figure:1 shows block diagram of poisonous gas detection using self localized robot. This robotic vehicle using ARM 7 controller is LPC 2148. This ARM 7 controller process the signal received from the set of sensors, location information from the GPS, and send these processed information's on the receiver side, via Wi-Fi. Robotic movement is controlled by the ARM.

In this robotic vehicle, GPS module can be used to give the location information to the ARM controller. In this robotic vehicle CO2 is taken as a poisonous gas, so CO2 sensor is used for it. Also, a temperature sensor can be used for measure temperature. An object detector can be used to detect any object in front of this robot. If any object is present in front of it, the vehicle will stop and sent information to the receiver side. Humidity sensor is used to measure humidity in that environment. Flame detector is used to measure the presents of flame. All these sensors are connecting to the ARM through an amplifier to amplify the analog signal. This analog signal can be converted to corresponding digital signal by using an analog to digital converter. In this case ADC is inbuilt in to the ARM. In these set of sensors, object sensor does not requires analog to digital converter, because it provide digital signals directly.

In this robotic vehicle use a belt type wheels to move the robotic vehicle on a rough surface. To control the movement of the robotic vehicle by using two driver circuits. Each of these driver circuits drives a relay for forward and backward movement. The LCD display shows the output of set of sensors and location information from GPS module.

In the receiver side, use a Wi-Fi receiver to receive information from the Wi-Fi transmitter. These received information given to an android application. The android mobile displays the presence of CO2 gas, temperature, humidity, and flame, location information and there levels with the help of application software.

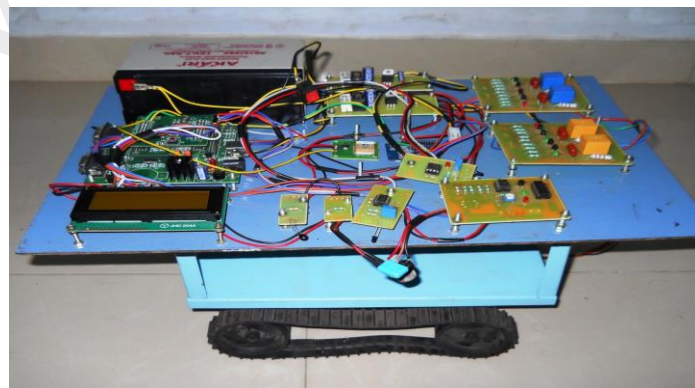

Figure 2: Model of the robotic vehicle

### B. Travel distance

The robotic vehicle operates its motors. Robotic vehicle may make turns or follow a curved path through adjusting the two sides of motors at different speeds and even in reverse direction. Speed of the robotic vehicle can be approximated by average of the speed of two sides of the motors. A motor may rotate either forward or backward. If the motor move in forward (backward) direction, the robotic vehicle may attempt to move in forward (backward).

## IV. CONCLUSION

Poisonous gas detection using self localized robot, a low-cost, self-contained, accurate localization system for small-sized ground robotic vehicles. Self localized robot localizes a robotic vehicle with an absolute positioning through a GPS receiver. The hardware devices Self localized robot are easily available at low cost. Self localized robot is self- contained in that it virtually requires no external devices or external facility management and that it needs no prior information. Unlike other localization schemes such as radio-based solutions, Self localized robot does not require external reference facilities, expensive hardware, careful tuning or strict calibration. The GPS-augmentation greatly enhances Self localized robot's resilience. This robot can be used to give there environmental conditions and also informing there levels.

## Acknowledgment

I would like to thank our Principal Dr. S .K. Masud Hossain, ,Head of the Department Prof. Jacob Zachariah ,our coordinator Asst. Prof. Sreetha Sreedhar and my guide Asst. Prof .Shilpa Harikumar for their valuable advice and technical assistance.

## References

- [1] K. Yu and I. Oppermann, "UWB Positioning for Wireless Embedded Networks," Proc. IEEE Radio and Wireless Conf., pp. 459-462, Sept. 2004.
- [2] A Practical Localization Algorithm Based on Wireless Sensor Networks, Tao Huang, Zhikui Chen, Feng Xia, Cheng Jin, Liang Li School of Software Dalian University of Technology Dalian 116620, China ht2411@hotmail.com, zkchen@dlut.edu.cn, f.xia@ieee.org, {jincheng117, liangli0917}@gmail.com.
- [3] Improving Energy Efficiency of Location Sensing on Smart phones. Zhenyun Zhuang<sup>1</sup>, Kyu-Han Kim<sup>2†</sup>, Jatinder Pal Singh<sup>2</sup> <sup>1</sup>Georgia Institute of Technology, Atlanta, GA 30332, U.S.A. <sup>2</sup>Deutsche Telekom R&D Laboratories USA, Los Altos, CA 94022, U.S.A. zhenyun@cc.gatech.edu, kyuhhan.kim@telekom.com, jatinder.singh@telekom.com Web.
- [4] Energy-Efficient Rate-Adaptive GPS-based Positioning for Smart phones Jeongyeup Paek Joongheon Kim Ramesh Govindan Embedded Networks Laboratory Computer Science Department University of Southern California {jpaek,joonghek,ramesh}@usc.edu
- [5] Lobot-low cost virtual machine for Localization 1s.suganya, 2b.kamalasoundari 1pg scholar, electronics and communication engineering, psna college of engineering and technology. 2assistant professor, electronics and communication engineering, psna college of engineering and technology.
- [6] G. Desouza and A. Kak, "Vision for Mobile Robot Navigation: a Survey," IEEE Trans. Pattern Analysis and Machine Intelligence, vol. 24, no. 2, pp. 237-267, Feb. 2002.
- [7] "LOBOT: Low-Cost, Self-Contained Localization of Small-Sized Ground Robotic Vehicles", Guoxing Zhan and Weisong Shi, Senior Member, IEEE

## Authors Short Profile:



Aswini P received the Engineering. degree in Electronics & Communication from Calicut University, in 2013, and Undergoing M.Tech degree in Digital Electronics from Kannur University (2013-2015)