



# Fault Management in Renewable Energy Resources

**Manikandan S<sup>1</sup>**  
PG Student (PSE),

Dept. of EEE,  
SNS college of Technology,  
Coimbatore, Tamilnadu, India<sup>1</sup>  
Manicracker@gmail.com

**Senthil Kumar R<sup>2</sup>**  
Assitant professor

Dept. of EEE,  
SNS college of Technology,  
Coimbatore, Tamilnadu, India<sup>2</sup>  
senkumarme@gmail.com

**Abstract -Renewable energy resources play a vital role in producing electricity for day today life especially (solar and wind energy generation). In this paper both sources have separately investigated in the system. Both sources connected to the grid. This paper discuss about the control operation of grid connected photovoltaic cell and grid connected wind energy conversion system when applying three phase fault to the system. Matlab/software was used to simulate the proposed system.**

**Index terms:** photovoltaic cell, boost converter, inverter, PI controller

## 1. INTRODUCTION

They are so many fuels in our country to produce electricity, But our day to day life running behind the renewable energy sources. Research increase in renewable energy resources connected to the grid, because it gives detailed information about the reliability ,security of the system when load changing and environment friendly . In this paper, separately deals about the two renewable energy resources connected to a grid, they are sun and wind because it only free resources. Now a days, the most important issues in power system are the power supply and the quality of the power. In order to resolve those issue, the solar and wind are commonly used. It s considered to be reliable because of its ability to produce power from the natural energy resources which is free, abundant, clean and also distributed over the earth[1].The designing of the active power filter has been completed by the instantaneous power theory which results a good performance [2]. The combination of the converter

with filter is discussed in[3]. Due to continuous use of fossil fuel, it created a detrimental greenhouse impacts on living beings. With the growing concern over environmental issue and the increase usage of dc loads for low cost, PV based systems are employed in diverse applications.

PV systems are broadly classified as stand-alone and grid connected systems. Stand-alone systems are popular in remote areas where electricity is not viable. The reliability of such systems are improved by usage of storage batteries. Grid connected systems allows to reduce our consumption from grid and in some instances, to feed surplus energy back to grid, which may give credit for energy returned. The improvement of power electronics has a positive impact on the grid connected PV systems

Detailed structure of grid connected renewable energy resources is discussed in [4]. Grid connected load and synchronization operation in [5]. The islanding of a system from a network when fault occurs is discussed in [6].The islanding of system from the network is overcome by controller and it does not affect the quality of the power supply.

## 2. STRUCTURE OF WIND SYSTEM

The conversion of wind energy into electric energy is shown in fig.1. Doubly fed induction generator is used in this system, because it is variable speed variable frequency system and it leads to high efficiency. Two controller used in DFIG for conversion purpose named as rotor side controller

and grid side controller.[8]

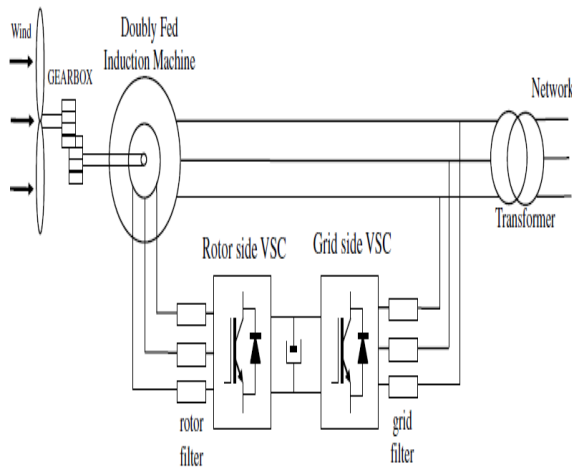

Fig 1: Equivalent circuit of DFIG

### 2.1 GRID SIDE AND ROTOR SIDE CONTROLLER:

Based on the variation of wind energy, controller have been operated .if the wind energy is low grid side controller extract power from the grid, then convert DC and transmit to rotor side controller through DC link. Then rotor side controller converts DC to AC and given as rotor excitation for generator and generated electricity transmitted to grid[9] . A number of pulse chosen is based on the power transferred.

### 2.2 SIMULATION OF WECS SYSTEM

This system is modeled by equation of wind turbine as could be seen in equation below. In this paper variable wind speed turbine s used. Wind speed 12 m/s is considered. If the wind of speed is variable, WECS should be used the buck boost converter[10]. If this case trigger signal should produce for two switches. This performance cause to system be complicated.

Equation of wind turbine is shown below[7].

$$p_m = 0.5 \times c_p(\lambda, \beta) \times \rho \times A \times v_w \quad (1)$$

$$c_p(\lambda, \beta) = c_1 \left( \frac{c_2}{\lambda_i} - c_3 \lambda - c_4 \right) e^{\frac{c_5}{\lambda_i}} + c_6 \lambda \quad (2)$$

$$\lambda = \frac{r_w}{v_w} \quad (3)$$

Output mechanical power in watts is shown in equation(8).

### 3. STRUCTURE OF SOLAR SYSTEM:

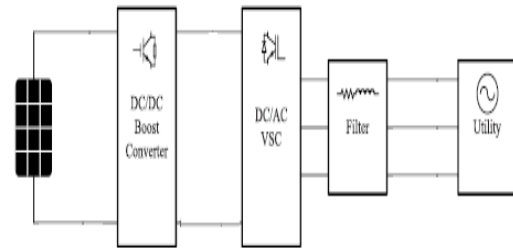

Fig 2: Equivalent circuit of solar system

Apart from wind, solar source is mostly used in industrial and home side applications. The solar system consists of solar panel DC/DC boost converter, Voltage source inverter, Filter and grid.

Non linear relationship between V-I obtain from the below equation[11],[12]

$$v_{pv} = \frac{N}{\lambda} \ln(i_{pv} - i_{pv} + M I_0 | M I_0) - \frac{N}{\lambda} R_s I_{pv} \quad (4)$$

According to related values equation (1) as follows

$$V_{PV} = 1.767 \ln \left( \frac{i_{sc} - i_{pv} + 0.0005}{0.0005} \right) - i_{pv} \quad (5)$$

By changing temperature , the coefficient will changes. Two sample of the changes are estimated in equation 6a and b.

$$v_{pv} = 1.69 \ln \left( \frac{3.005 - i_{pv} + 0.0024}{0.0024} \right) - i_{pv} \quad (6a)$$

$$v_{pv} = 1.82 \ln \left( \frac{2.83 - i_{pv} + 0.0001}{0.0001} \right) - i_{pv} \quad (6b)$$

The combination of MOSFET with PI controller extract maximum power from panel. It increase the reliability of the system[13]. They extract power transmitted to the DC/DC boost converter. DC/DC boost converter consist of diode and IGBT switch 90V from the panel is boosted to 180V by boost converter. The purpose of choosing IGBT is it have high frequency switching characteristics. Inverter which convert DC/AC from



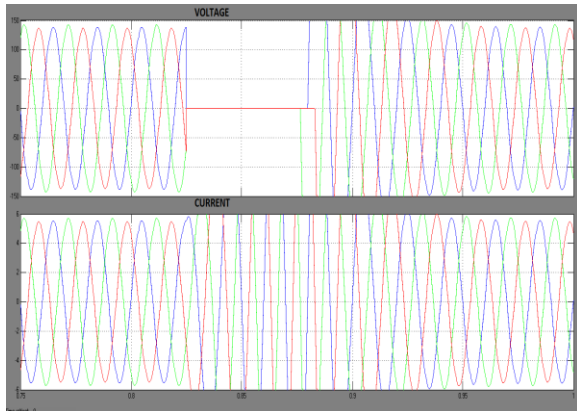

Fig 6: Output voltage and current with fault

Fig 7 shows that the output voltage and current of solar system without fault condition by using controller technique

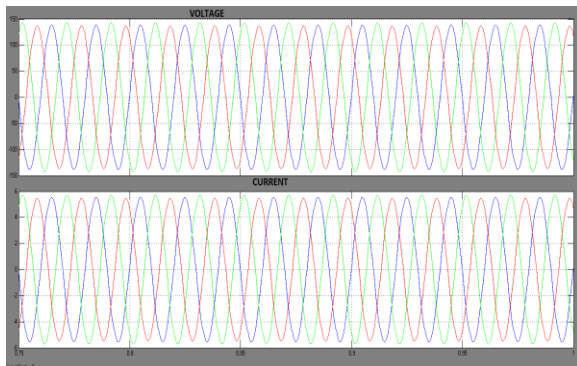

Fig 7: Output voltage and current without fault

## 5.2 OUTPUT FOR WIND SYSTEM

This figure shows that the output voltage and current of the wind system of 580V.

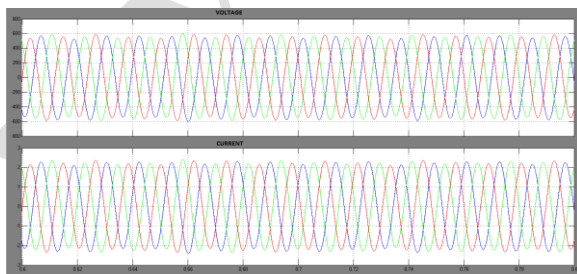

Fig 8: output voltage and current of wind system.

Fig 9 shows that the output voltage and current of wind system with fault condition

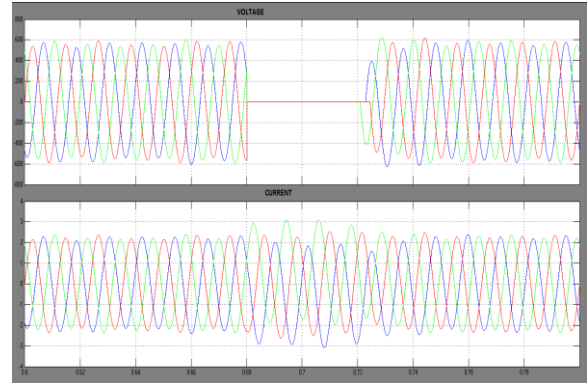

Fig 9: Output voltage and current with fault

Fig 10 shows that the output voltage and current of wind system without fault condition

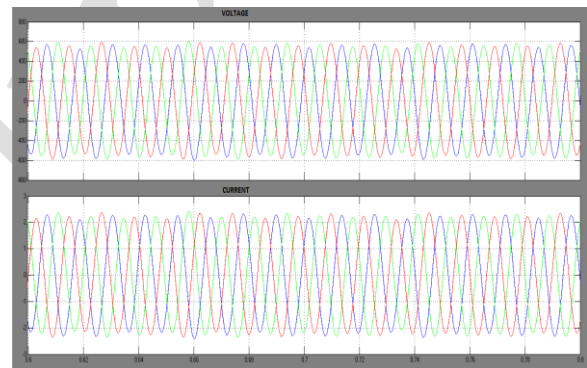

Fig 10: Output voltage and current without fault

## 6. CONCLUSION

In this paper a grid connected renewable energy resources and grid side controller has simulated. Control principles and modeling of the system has investigated. Output of the system displayed for three load arrangement. By means of showing load management and support of loads in developed systems, Fault management and control vision has showed. And energy storage operation in the moment of load respond and when loads have the changes has displayed. Of course it could be seen that in all conditions the system can continue to stable operation and loads are in good respond condition.



## REFERENCES

- [1]B. Lasseter, "Microgrids (Distributed Power Generation)," *Proceedings of the IEEE PES Winter Meeting*, Vol. 1, 2001, pp. 146-149.
- [2]N. Hatziargyriou, H. Asano, R. Iravani and C. Marnay, "Microgrids: An Overview of Ongoing Research, Development, and Demonstration Projects," *IEEE Power Energy Magazine*, Vol. 5, No. 4, 2007, pp. 78-94. doi:10.1109/MPAE.2007.376583
- [3]M. Pipattanasomporn, H. Feroze and S. Rahman, "Multi-Agent Systems in a Distributed Smart Grid: Design and Implementation," *Power Systems Conference and Exposition*, Seattle, 15-18 March 2009, pp. 1-8.
- [4]Public Power Corporation, "Microgrids—Large Scale Integration of Micro-Generation to Low Voltage Grids," Technical Annex, 2002.
- [5]P. Piagi and R. H. Lasseter, "Autonomous Control of Microgrids," *IEEE PES Meeting*, Montreal, June 2006.
- [6]C. L. Moreira, F. O. Resende and J. A. P. Lopes, "Using Low Voltage MicroGrids for Service Restoration," *IEEE Transactions on Power Systems*, Vol. 22, No. 1, 2007, pp. 395-403.
- [7]R. Zamora and A. K. Srivastava, "Controls for Microgrids with Storage: Review, Challenges, and Research Needs," *Elsevier*, Vol. 14, No. 7, 2010, pp. 2009-2018.
- [8]F. Katiraei, M. R. Iravani and P. W. Lehn, "Microgrid Autonomous Operation during and Subsequent to Islanding Process," *IEEE Transactions on Power Delivery*, Vol. 20, No. 1, 2005, pp. 248-257.
- [9]D. Georgakis, S. Papathanassiou, N. Hatziargyriou, A. Engler and C. Hardt, "Operation of a Prototype Microgrid System Based on Micro-Sources Equipped with Fast-Acting Power Electronics Interfaces," *Proceedings of IEEE 35th PESC*, Aachen, Vol. 4, 2004, pp. 2521-2526.
- [10]F. Blaabjerg, R. Teodorescu, M. Liserre and A. V. Timbus, "Overview of Control and Grid Synchronization for Distributed Power Generation Systems," *IEEE Transactions on Industrial Electronics*, Vol. 53, No. 5, 2006, pp. 1398-1409.
- [11]M. Uzunoglu, O. C. Onar and M. S. Alam, "Modeling, Control and Simulation of a PV/FC/UC Based Hybrid Power Generation System for Stand-Alone Applications," *Renewable Energy*, Vol. 34, No. 3, 2009, pp. 509-520. doi:10.1016/j.renene.2008.06.009
- [12]Z. M. Salameh, B. S. Borowy and A. R. A. Amin, "Photovoltaic Module-Site Matching Based on the Capacity Factors," *IEEE Transactions on Energy Conversion*, Vol. 10, No. 2, 1995, pp. 326-332. doi:10.1109/60.391899
- [13]M. A. Masoum, H. Dehbonei and E. F. Fuchs, "Theoretical and Experimental Analyses of Photovoltaic Systems with Voltage- and Current-Based Maximum Power-Point Tracking," *IEEE Transactions on Energy Conversion*, Vol. 22, No. 8, 2002, p. 62.
- [14]W. I. Rowen, "Simplified Mathematical Representations of Heavy Duty Gas Turbines," *Journal of Engineering for Power*, Vol. 105, No. 4, 1983, pp. 865-869. doi:10.1115/1.3227494
- [15]L. N. Hannet and A. Khan, "Combustion Turbine Dynamic Model Validation from Tests," *IEEE Transactions on Power Systems*, Vol. 8, No. 1, 1993, pp. 152-158.
- [16]A. K. Saha, S. Chowdhury, S. P. Chowdhury and P. A. Crossley, "Modeling and Performance Analysis of a Micro-turbine as a Distributed Energy Resource," *IEEE Transactions on Energy Conversion*, Vol. 24, No. 2, 2009, pp. 529-538.
- [17]Working Group on Prime Mover and Energy Supply Models for System Dynamic Performance Studies, "Dynamic Models for Combined Cycle Plants in Power System Studies," *IEEE Transactions on Power Systems*, Vol. 9, No. 3, 1994, pp. 1698-1708. doi:10.1109/59.336085
- [18]I. Zamora, J. S. Martin, A. Mazon, J. S. Martin and V. Aperribay, "Emergent Technologies in Electrical Micro-generation," *International Journal of Emerging Electric Power Systems*, Vol. 3, No. 2, 2005, pp. 1553-1779.
- [19]C.-M. Ong, "Dynamic Simulation of Electric Machinery Using Matlab/Simulink," Prentice Hall, Upper Saddle River, 1998.