



# HVDC POWER TRANSMISSION SYSTEM USING SOFT SWITCHING TECHNIQUE TO REDUCE SWITCHING POWER LOSS

Shakila.C  
P.G.Student  
M.E. Power System Engineering  
Kingston Engineering college  
shakilagit@gmail.com

Venugopal.R  
Assistant Professor  
Kingston Engineering College

## Abstract

This paper presents reduction of power loss in HVDC power transmission by employing soft switching technique. The major drawback of hard switching is conventional topology is eliminated due to usage of soft switching technique. Zero current switching allows the switches to turn on and turn off at the zero voltage. The zero voltage switching technique is more efficient than zero current switching technique. Hence the switching power loss is reduced by the usage of zero voltage switching of the technique. Switching power loss in the HVDC circuit is reduced compare to the conventional circuits. Due to reduced switching loss, the efficiency of the system increases. A simulation in MATLAB is done to study the performance of the reduced power loss in HVDC transmission system. The same is to be implemented in hardware prototype to study the performance practically.

## I. INTRODUCTION

Recently, HVDC transmission system has been used in some countries because of its advantage in long distance bulk power transmission and full control over power transmitted. Fast control to limit the fault current in DC lines, stability limit, voltage control limit. The power converters are important for the HVDC transmission system. The HVDC transmission system, now days usage of flexible and efficient power transfer by self turn off devices. The self turn of devices are having some limitations such as voltage stress, current stress, high switching loss and electromagnetic noise generation. The self turn off self turn off devices such as the IGBT, MOSFET, GTO are used for the solution of this problem includes improving performance of power switches and HVDC circuit topology. The switching loss is reduced by using soft switching technique, the soft switching technique is classified in to the two types such as zero current switching and zero voltage switching technique. The zero current switching technique means converter switches turn on and turn off at zero current. The zero voltage switching technique means converter switches turn on and turn off at zero voltage. MOSFET switches are widely used in converter and improve the performance of the HVDC transmission system because MOSFET is high voltage and has high current handling capacity. The switching technique will play an important role in future electric power transmission. The HVDC transmission system is more efficient for the HVAC transmission beyond the critical limit 500km to 800km.

## OBJECTIVES

To transmit high power with high efficiency in HVDC transmission system.

To identify the problems associated with the existing converter and to modify the converter to overcome the problems identified.

To reduce switching power loss

To reduce voltage and current stress

.HVDC TRANSMISSION SYSTEM CIRCUIT DIAGRAM

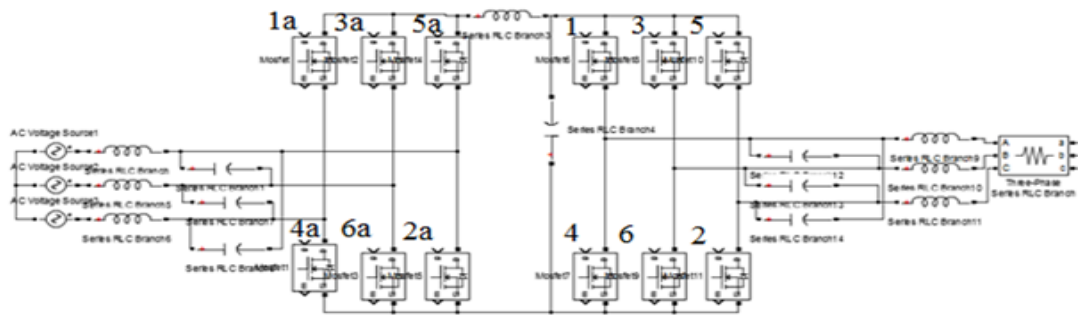

The HVDC transmission system circuit diagram as shown in Fig.1

### MODES OF OPERATION

#### Mode(1):

As the initial mode converter switches 1,2 turn on and turn off. The converter circuit attains a resonant condition by inductor and capacitor. The resonant converter voltage flow through the converter circuit.

#### Mode(2):

The resonant voltage flows through the converter circuit side. When the converter voltage flow through the zero. The converter switches turn on and turn off at zero voltage switching respectively. After switching on and switching off of the main devices, the converter voltage flow through the primary devices.

#### Mode(3)

When the converter circuit is again in resonant condition the capacitor changes the reverse polarity by the flow converter voltage. The converter voltage is zero when is turn on and turn off of the zero voltage switching. This conditions shifts to mode (4).

#### Mode(4)

When the voltage flowing through the converter is zero, the current changes the reverse polarity and the voltage flows through the primary inverter.

#### Mode(5)

The reverse polarity of the current turns on signal of the converter switches 2a and 5a and the current flows through the reverse direction in the converter circuit. When the converter voltage reaches zero. Then the converter operating mode shifts to the next mode of operation.

#### Mode(6)

In this mode the voltage is zero. Now turn on signal of the converter switches 2a and 5a the converter circuit repeats similar operating modes of operation 1

## II. HARD SWITCHING OF HVDC TRANSMISSION SYSTEM SIMULATION DIAGRAM

The hard switching technique means converter switches turn on and turn off at certain maximum voltage level. The hard switching technique increase the overlap angle between the voltage and current. The hard switching technique is made up of some problems and the problems overcome by

soft switching technique. The Hard switching of HVDC transmission system simulation diagram as shown in Fig.2

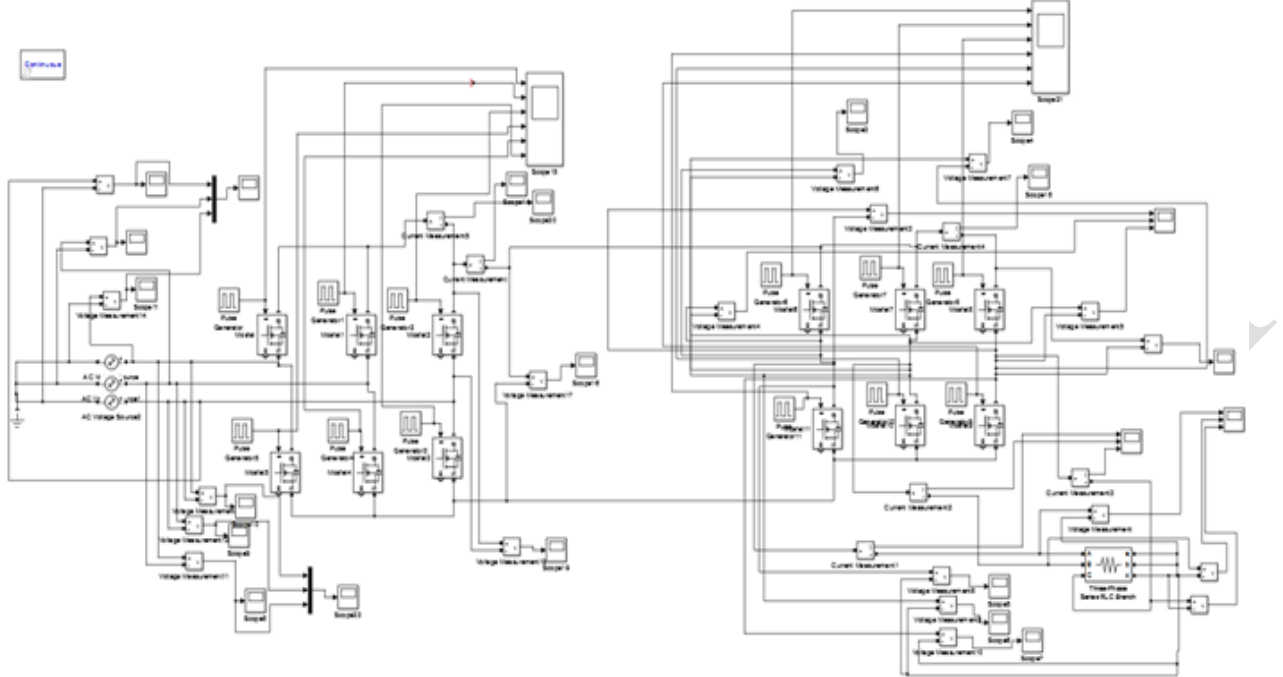

Fig.2.Hard switching HVDC Transmission simulation diagram

### III. HARD SWITCHING OF HVDC TRANSMISSION SYSTEM SIMULATION RESULTS

#### A.CONVERTER INPUT LINE VOLTAGE WAVEFROM

The converter input line voltage waveform is along the positive half cycle to the negative cycle such that the waveform level is between -400 Voltage to 400 Voltage. The converter input line voltage waveform X axis represents the time and Y axis represents voltage. The converter input line voltage waveform as shown in Fig.3.

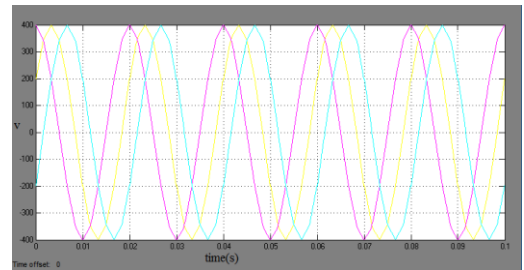

Fig.3.Converter input line voltage waveform

#### B.CONVERTER INPUT PHASE VOLTAGE WAVEFORM

The converter input phase voltage waveform along the positive half cycle changes to negative half cycle such that the waveform level is -230 voltage to 230 voltage. The converter input phase voltage waveform X axis represents the time and Y axis represents the voltage. The converter input phase voltage waveform as shown in Fig.4

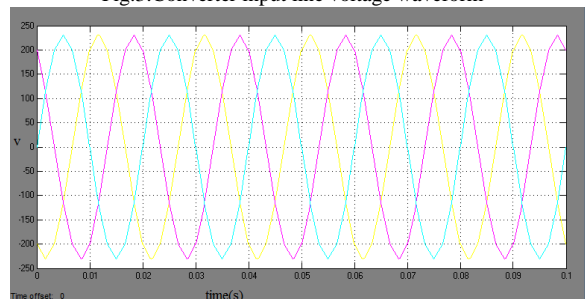

Fig.4.converter input phase voltage waveform

### C. SWITCHING PULSE OF THE CONVERTER SWITCHES

The switching pulse of the converter switching waveform X axis represents the time and Y axis represents the voltage. Switching pulse of the converter switching voltage is 10V. The switching pulse of the converter switching waveform as shown in Fig.5

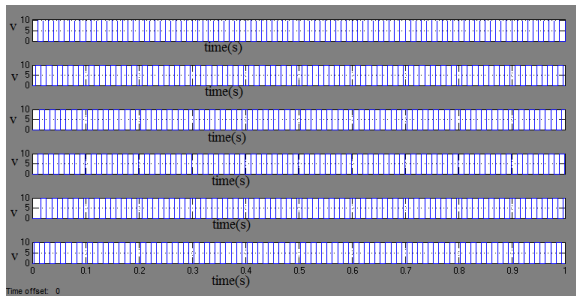

Fig.5. Switching pulse of the converter switches

### D. CONVERTER OUTPUT VOLTAGE WAVEFORM

The converter output voltage waveform represents the X axis is time and Y axis represents the voltage. Converter output voltage waveform is 400V. The converter output voltage waveform as shown in Fig.6

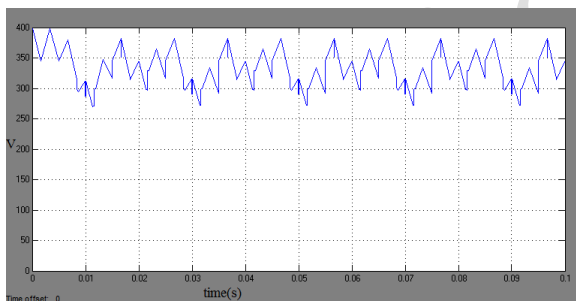

Fig.6. Converter output voltage waveform

### E. CONVERTER OUTPUT CURRENT WAVEFORM

The converter output current waveform X axis represents the time and Y axis represents the voltage. Converter output current waveform the varies from -4000V to 4000V. The converter output current waveform as shown in Fig.7

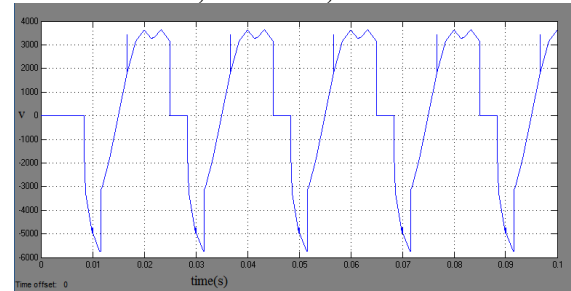

Fig.7. Converter output current waveform

### F. VOLTAGE STRESS ACROSS CONVERTER SWITCHES

The voltage stress across converter switching waveform X axis represents the time and the Y axis represents the voltage. The voltage stress across converter switching voltage varies 50V to 350V. The voltage stress across converter switching waveform as shown in Fig.8

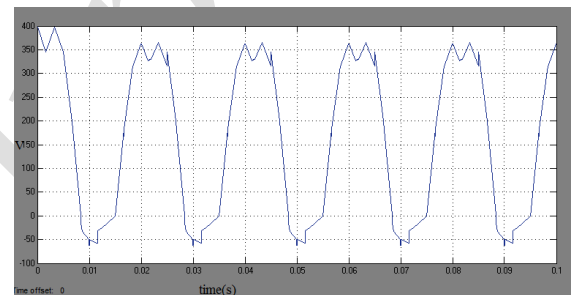

Fig.8. Voltage stress across converter switching waveform

### H. INVERTER OUTPUT CURRENT WAVEFORM

The inverter output current waveform X axis represents the time and Y axis represents the current. The inverter output current is 5A. The inverter output current waveform as shown in Fig.10.

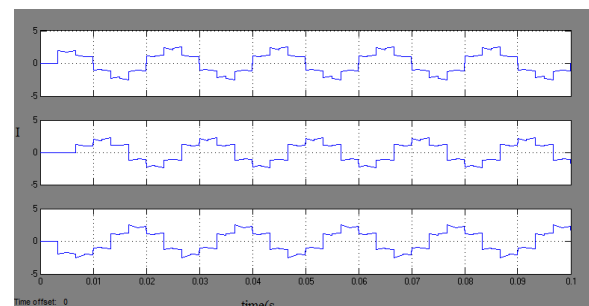

Fig.10. Inverter output current waveform

**G. CURRENT STRESS ACROSS CONVERTER SWITCHES**

The current stress across converter switching waveform X axis represents the time and Y axis represents current. The current stress across the converter switches is 5A. The current stress across converter switching waveform as shown in Fig.9.

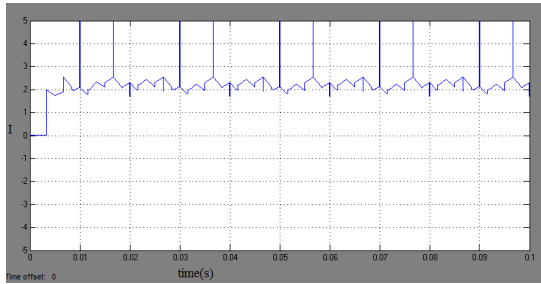

Fig.9. Current stress across converter switching waveform

**J. INVERTER OUTPUT CURRENT WAVFORM**

The inverter output current waveform X axis represents the time and Y axis represents the current. The inverter output current waveform along the positive cycle to negative cycle varies from -5 voltage to 5 voltage. The inverter output current waveform as shown in Fig.11

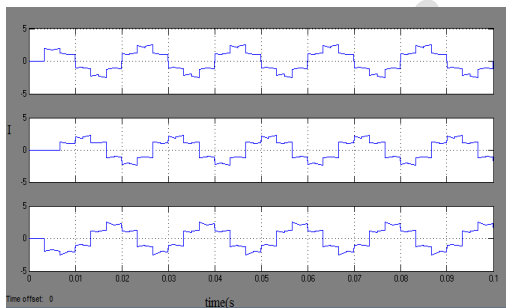

Fig.11. Inverter output current waveform

**K. INVERTER OUTPUT LINE VOLTAGE**

The inverter output line voltage waveform X axis represents the time and Y axis represents the voltage. The inverter output line voltage is -400 voltage to 400 voltage. The inverter output line voltage waveform as shown in Fig.12

**I. INVERTER OUTPUT PHASE VOLTAGE WAVEFORM**

The inverter output phase voltage waveform X axis represents the time and Y axis represents the voltage. The inverter output phase voltage varies from -230 voltage to 230 voltage. The inverter output phase voltage waveform as shown in Fig.10.

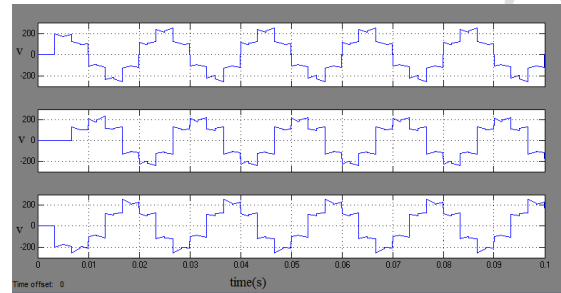

Fig.10. Inverter output phase voltage waveform

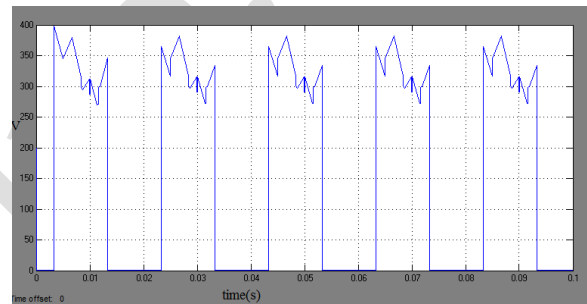
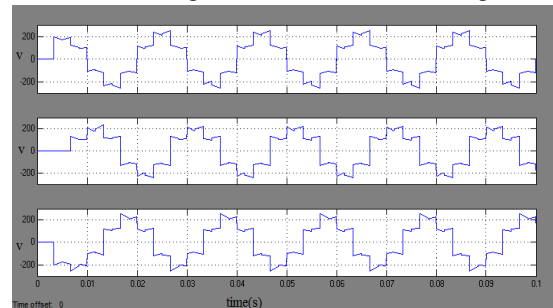

Fig.13. Voltage stress across inverter switching waveform

**M. SWITCHING PULSE ACROSS INVERTER SWITCHING**

The switching pulse of the inverter switching voltage is 10 voltage. The switching pulse across inverter switching waveform as shown in Fig.14



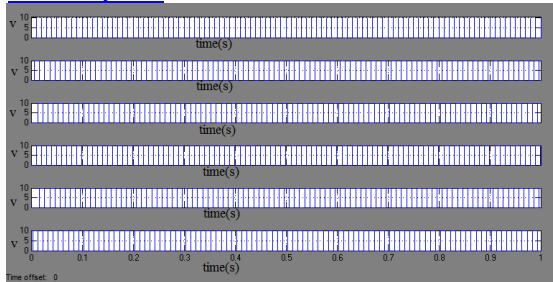

Fig.12.Inverter output line voltage waveform

#### L. VOLTAGE STRESS ACROSS INVERTER SWITCHES

The voltage stress across inverter switching waveform X axis represents the time and Y axis represents the current. The voltage stress across inverter switch is 400 voltage. The voltage stress across inverter switching waveform as shown in Fig.13

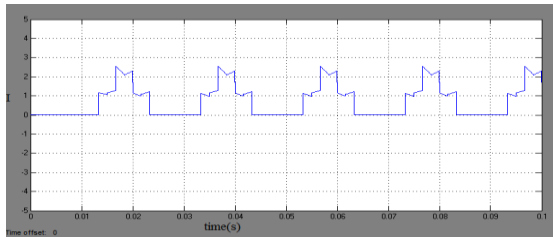

Fig.15.Current stress across inverter switches

#### N.CURRENT STRESS ACROSS INVERTER SWITCHES

The current stress across inverter switch is 2.5A.The current stress across inverter switching waveform as shown in Fig.15.

#### IV. SOFT SWITCHING TECHNIQUE OF HVDC TRANSMISSION SYSTEM RESULTS

##### A. CONVERTER INPUT LINE VOLTAGE WAVEFORM

The converter input voltage waveform X axis represents the time and Y axis represents the voltage. The converter input line varies from -400 voltage to 400 voltage. The converter input line voltage waveform as shown in Fig 16

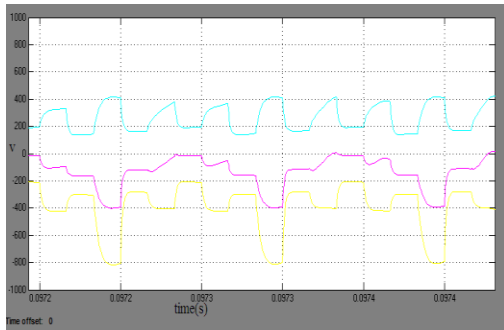

Fig.16.Converter input line voltage waveform

##### B. CONVERTER INPUT PHASE VOLTAGE WAVEFORM

The converter input phase voltage varies from -230 voltage to 230 voltage. The converter input voltage waveform as shown in Fig.17.Converter input phase voltage waveform

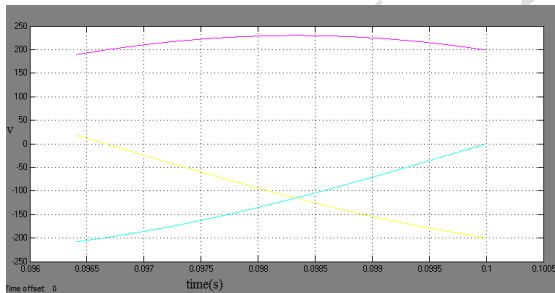

Fig.17.Converter input phase voltage waveform

##### C. SWITCHING PULSE OF THE CONVERTER SWITCHES

The switching pulse of the converter switching waveform X axis represents the time and voltage. The switching pulse of the converter switching

voltage is 10 voltage. The Switching pulse of the converter switches as shown in Fig.18

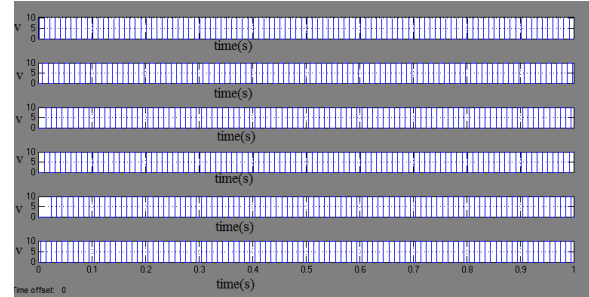

Fig.18.Switching pulse of the converter switches

##### D. CONVERTER OUTPUT VOLTAGE WAVEFORM

The converter output voltage waveform X axis represents the time and Y axis represents the voltage. The converter output voltage is 350 voltage. The converter output voltage waveform as shown in Fig.19

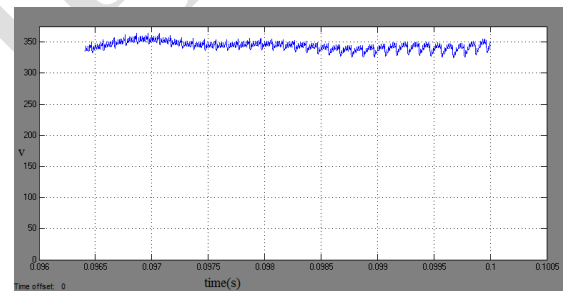

Fig.19.Converter output voltage waveform

##### E. CONVERTER OUTPUT CURRENT WAVEFORM

The converter output current waveform X axis represents the time and Y axis represents the current. The converter output current waveform varies from 50A to 110A. The converter output current waveform is shown in Fig.20

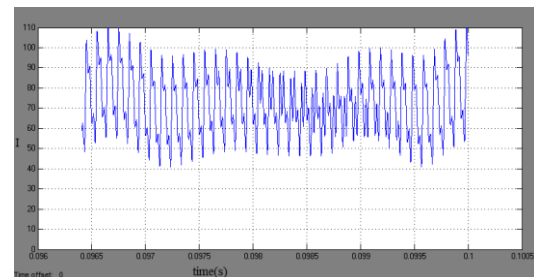

Fig.20.Converter output current waveform

### F. VOLTAGE STRESS ACROSS CONVERTER SWITCHES

The voltage stress across converter switching waveform X axis represents the time and Y axis represents the voltage. The voltage stress across converter switching voltage varies from 100V to 700V. The voltage stress across converter switching waveform as shown in Fig.21

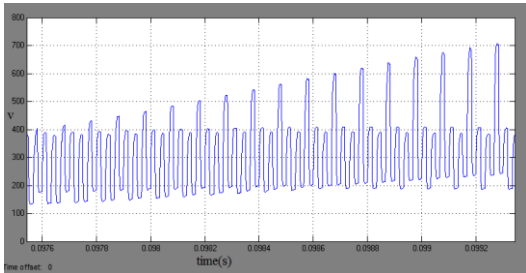

Fig.21.Voltage stress across converter switching waveform

### G. CURRENT STRESS ACROSS CONVERTER SWITCHES

The current stress across converter switching waveform X axis represents the time and Y axis represents the current. The current stress across converter switching waveform varies from 0A to 4000A. The current stress across converter switching waveform as shown in Fig.22

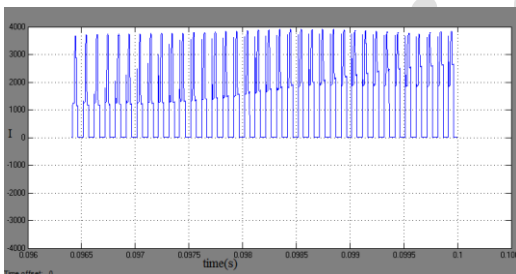

Fig.22.Current stress across converter switches

### H. INVERTER OUTPUT CURRENT WAVEFORM

The inverter output current varies from -500A to 500A. The inverter output current waveform as shown in Fig.23

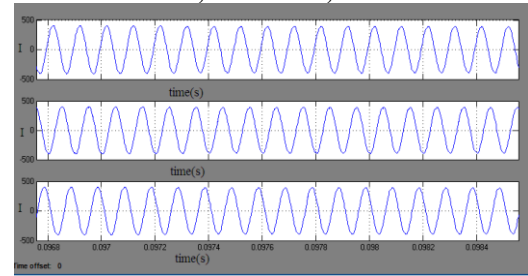

Fig.23.Inverter output current waveform

### J. INVERTER OUTPUT LINE VOLTAGE WAVEFORM

The inverter output line voltage waveform X axis represents the time and Y axis represents the voltage. The inverter output line voltage varies from -400V to 400V. The inverter output line voltage waveform as shown in Fig.24

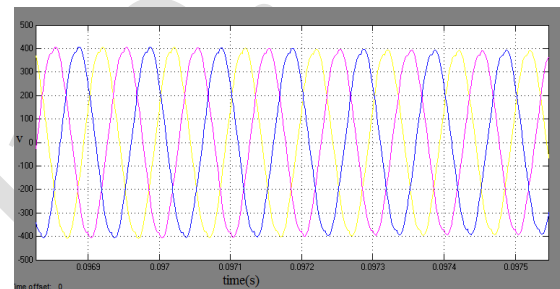

Fig.24.Inverter output line voltage waveform

### K. INVERTER OUTPUT PHASE VOLTAGE WAVEFORM

The inverter output phase voltage waveform X axis represents the time and Y axis represents the voltage. The inverter output phase voltage waveform varies from -500V to 500V. The inverter output phase voltage waveform as shown in Fig.25

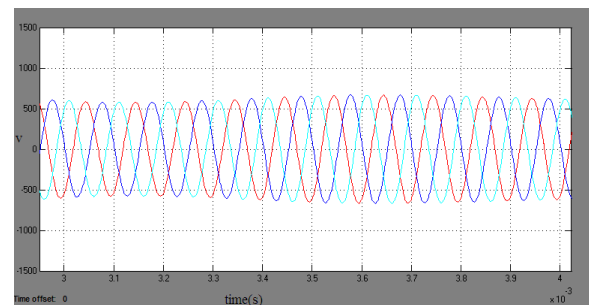

Fig.25.Inverter output phase voltage waveform

### L. SWITCHING PULSE ACROSS INVERTER SWITCHES

The switching pulse of the inverter switches X axis represents the time and Y axis represents the voltage. The switching pulse of the inverter switching voltage is 10V. The switching pulse across inverter switching waveform as shown in Fig.26

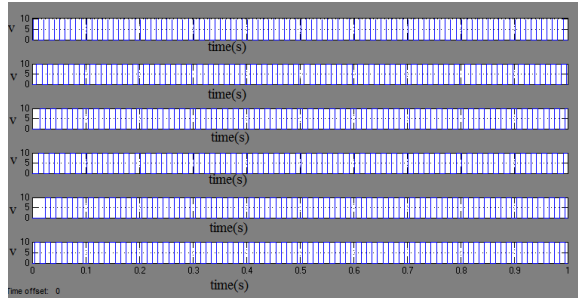

Fig.26.Switching pulse across inverter switching waveform

#### M. VOLTAGE STRESS ACROSS INVERTER SWITCHES

The voltage stress across inverter switching waveform X axis represents time and Y axis represents the voltage. The voltage stress across inverter switching voltage varies from -350A to 350A. The voltage stress across inverter switching waveform as shown in Fig.27

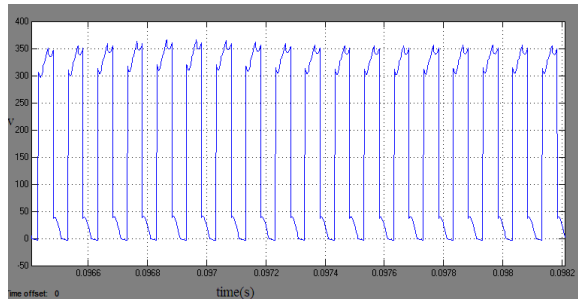

Fig.27.Voltage stress across inverter switching waveform

#### REFERENCES

- [1] T.snju, K.Kurohanu,J.Miyagi “low loss HVDC power transmission system with self commutated power converter introducing zero current soft switching technique” IET Trans.October,2008.
- [2] A.Shonknecht, Dedoncker.A, “Novel topology for parallel connection of soft switching high power high frequency inverters”,IEEE Trans, pp 550-555 ,2003.
- [3] H.Suzuki, Nakajima .K,Sugimoto, “Development and testing of prototype models for a high performance 300MW self commutated AC/DC converter”,IEEE Trans.Power Deliv 12,pp.1589-1597,1997.
- [4] K.Takao,Yatsuo.T,Arai.K, High di/dt Switching characteristics of a sic scottly barrier diode” ,IEEJ Trans.pp.917-923,2004.
- [5] P.Tomasin “A novel topology of zero current switching voltage source PWM inverter for high power applications”,IEEE Trans,pp.186-193,1998.
- [6] Dr.Chandra Sekar “Zero voltgae and zero current switching converters”, IET Trans.,2010.

#### N. CURRENT STRESS ACROSS INVERTER SWITCHES

The current stress across inverter switching waveform varies from -350A to 350A. The current stress across inverter switches as shown in Fig.28

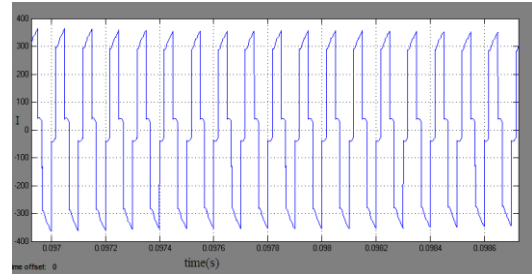

Fig.28.Current stress across inverter switching waveform

#### V. CONCLUSION

The HVDC power transmission employing soft switching technique with reduced power loss using zero voltage switching technique is simulated. The hard switching and soft switching were implemented and compared. Out of Comparison it is found while employing soft switching technique. The switching power loss is reduced. Since the results of hard technique tells us that the switching power loss is 192 W and the result of soft switching shows the switching loss is to be zero. Thus the efficiency of the HVDC system increases due to the reduced power loss by implementing soft switching technique.

The simulation of hard switching and soft switching of HVDC power transmission system presented and the results of the simulation was discussed detail.



- [7] Er.Harriet singh,snigdha Sharma,' "Switching Techniques in Mosfet" International journal ,Volume:2.
- [8] P.Li, Lee.F.c,Boro yevich.D, "IGBT device application aspects for 50 KW transition inverters"IEEE Trans.Apr,2004.
- [9] K.Padiyar "High voltage D C Transmission System".

WWW.IJIRP.COM