

Genetic Algorithm Based Approach for Optimization of Harmonic Function in Hybrid Multilevel Inverter

Uma. S¹
Assistant professor¹, Nandha College of Technology¹
Umasenthil.2007@gmail.com¹

Aiswarya.S²
Assistant professor², Mahendra Engineering
College²
aishu1309@gmail.com²

Abstract—Meta heuristics, such as the genetic algorithm (GA), have been used with success to compute optimal switching angles for hybrid multilevel inverters with many dc sources while minimizing several harmonics. Hybrid multi level inverters of 15 level inverters using 12 switches to minimizing harmonics and the optimization is proposed in order to accelerate the computation of the optimal switching angles for hybrid multilevel inverters with varying dc sources. Multilevel inverters form a popular class of high power inverters due to their high-voltage operation, high efficiency, low switching losses, and low electromagnetic interference. The proposed solution optimizes hybrid multi-level inverters with four variable dc sources while minimizing the harmonics in 20 mille seconds. Simulation of cascaded H-Bridge multilevel inverter of single phase 15- level cascaded multilevel inverter is presented and the output waveforms were observed using MATLAB.

Keywords: Optimization; Genetic algorithm; minimization; cascaded multi level inverter

I. INTRODUCTION

Hybrid Multilevel inverters use multiple H-bridge modules that are cascaded and connected to a series of dc voltage sources to produce an ac output by generating a stair case waveform. The control of the inverter is done by adjusting the switching angles to get the desired modulation index while minimizing the harmonics. Recent works aim to accelerate harmonic minimization in multilevel inverters using a parallel genetic algorithm on graphical processing unit.

In recent literature, many different approaches have been successfully used. Deterministic methods such as Newton Raphson method and Artificial Neural Network (ANN) are used to control three and four level source inverters. Other different approaches use Meta heuristics such as the genetic algorithm (GA) and the particle swarm optimization (PSO), or the bee algorithm. Meta heuristics have the advantage of scaling very well to large problem sizes.

Optimization is the act of obtaining the best result under given circumstances. In design construction and maintenance of any engineering system, engineers have to take many technological and managerial decisions at several stages. Optimization can be taken to mean minimization since the maximum of a function can be found by seeking the minimum of the negative of the same function. An optimization algorithm is a procedure which is executed iteratively by comparing various solutions till the optimum or a satisfactory solution is found. In many industrial design activities, optimization is achieved indirectly by comparing a few chosen design solutions and accepting the best solution. Optimization algorithms begin with one or more design solutions supplied by the user and then iteratively check new design solutions in order to achieve the true optimum solution.

Modern Metaheuristic algorithms have been developed with an aim to carry out global search, typical examples are genetic algorithms (Glodberg 1989), particle swarm optimization (PSO) (Kennedy and Eberhart 1995, Kennedy et al 2001). The efficiency of Metaheuristic can be attributed to the fact that they imitate the best features in nature, especially the selection of the fittest in biological systems which have evolved by natural selection over millions of years. Two important characteristics of metaheuristics are: intensification and diversification (Blum and Roli 2003, Gazi and Passino 2004, Yang 2009). Intensification intends to search around the current best solutions and select the best candidates or solutions, while diversification makes sure that the algorithm can explore the search space more efficiently, often by randomization.

II. HYBRID MULTI LEVEL INVERTER TOPOLOGY

The hybrid multi level inverter is a series connection of cascade half bridge cell and H-bridge inverter. In recent years multilevel inverters have been paying attention on and preferred as high power and high voltage ones [5]. Use of multilevel inverters is becoming popular for high power applications especially in the distributed generation where a number of batteries, fuel cells, solar cell, and micro-turbines can be connected through a multilevel inverter to feed a load or the ac grid without voltage balancing problems. Another major advantage of hybrid multilevel inverters is that their switching frequency is lower than a traditional low-level inverter, which leads to reduced switching losses. The topologies for high power multilevel inverters are classified into three types as shown in Fig 1. The diode clamped inverter, the flying capacitor inverter and the cascaded inverter [5].

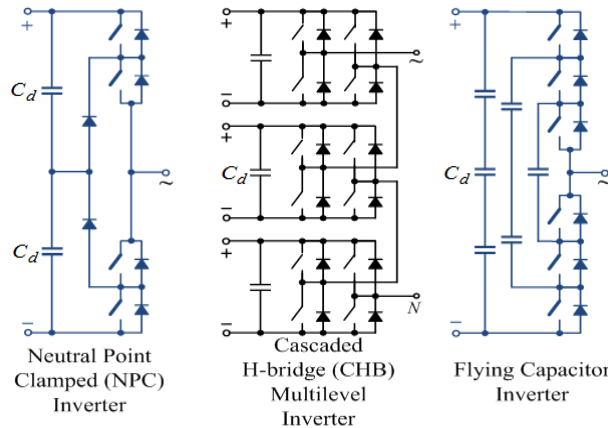

Fig 1: Multilevel Inverter Topologies

Among these inverters, the cascaded inverter has the advantages that the DC-link voltage is balanced, circuit layout flexibility, Cascaded multilevel inverter architecture has the ability to tolerate a fault for several cycles but if the fault type and location can be detected and identified, compared with the diode-clamped and flying capacitor inverters it requires the least number of components to achieve the same number of voltage levels, switching patterns and the modulation index of other active cells can be adjusted to maintain the operation under a balanced load condition.

Multilevel PWM and harmonic eradication are techniques that can be used in cascade multilevel inverters in order to achieve voltage waveforms with low total harmonic distortion (THD) with minimum switching losses and low filtering necessities. Using a multilevel layout, an effectual high switching frequency can be achieved in the output voltage waveform with each of the H-bridge modules having a relatively low switching frequency as shown in Fig 2. This approach will facilitate increased converter efficiency. Tumbling the filtering requirements would help to reduce the cost and improve the reliability and dynamic performance of the whole system.

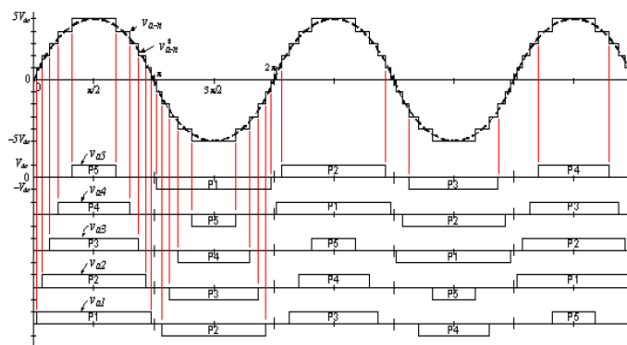

Fig2: Low loss low switching frequency multilevel inverter waveforms.

III. GENETIC ALGORITHM

The Genetic Algorithm, introduced by John Holland (1962), is a search algorithm that works over a population of encoded design variables to solve a given problem. GA mimics the trend of natural evolution, species search for progressively more valuable adaptations survival within their complex environments. The search takes place in the species' chromosomes where changes, and their effects, are graded by the endurance and reproduction.

Genetic algorithm (GA) is a technique based on the evolutionary process, where individuals are constantly adapting to a changing environment in order to survive. It mimics the activities of populations during generations, based on the thought that

the best-suited individuals have greater probability to endure and pass on their genetic codes to their descendants. Through generations, the quality of the population tends to improve.

Different approaches can be used to solve for the angles and the choice is application dependent. As the number of dimensions increases, the complexity and time to solve the equations increase. Analytical or numerical approaches may need computational power beyond current mathematical software. The harmonic minimization problem is solved using Particle Swarm Optimization (PSO) to find 15 switching angles. Another stochastic technique is Genetic Algorithm which will be adopted in this work mainly because it is well known and documented technique with a matured Mat lab toolbox.

A. Initiation

At the beginning of iterations, GA generates some set of random solutions to form the initial population. Alternatively, this can be done by seeding the population with known fit chromosomes.

B. Evaluation

The Evaluation phase simply provides a way to rate how each chromosome solves the problem under consideration. It involves decoding of the chromosomes into the variable space of the problem and then checking the result of the problem using these parameters. Then the fitness is computed from the result.

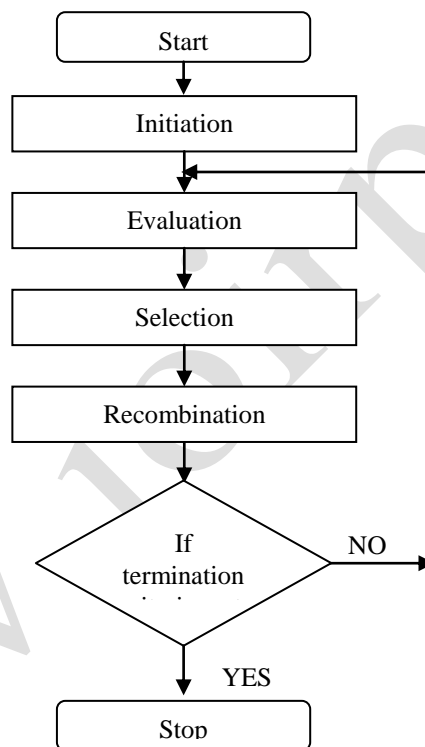

Fig 3: Flowchart of Genetic Algorithm

C. Selection

Selection is quite possibly the most important and most misunderstood part of GA. In this phase, chromosomes are selected for proliferation to future populations based on their fitness. This selection process is a double-edged sword. If selection involves only the highest-fit chromosomes, the solution space becomes very limited due to lack of diversity. If selection is performed randomly, there is no guarantee that future generations will increase the quality of solution.

The result of the selection process is a set of chromosomes that will take part in recombination. Large varieties of selection algorithms exist. Roulette-wheel is one of the most widely used selection algorithm in GA. Other selection algorithms include tournament selection, rank-based selection, progeny testing, individual selection, family selection, within-family selection and combined selection. Roulette-wheel selection performs selection from the population based upon the fitness of the chromosome. The higher-fit chromosome is more likely to be chosen for propagation to the next generation. In other words, the probability of selection is proportional to the fitness of the chromosome. A sample Roulette-wheel selection is shown in Fig 4.

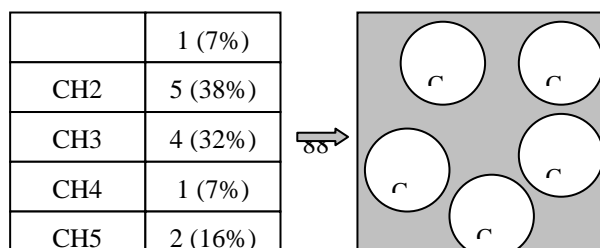

Fig 4: Roulette Wheel Selection Procedures

In Fig 4, CH1...CH5 represent the chromosomes in a particular generation along with their fitness value. Since the chromosome (CH2) has higher fitness value, it is copied twice for future generation. Similarly CH3 and CH5 are copied according to the fitness value. Chromosomes CH1 and CH4 are not selected at all and they disappear from the subsequent population.

D. Recombination

In recombination, pairs of chromosomes are recombined, possibly modified and then placed back into the population as the next generation. The original sets of chromosomes are generally called as “parents” and the resulting modified chromosomes are the “children or offspring”. One or more genetic operators are applied on the chromosome with some probability. Crossover and Mutation are widely used genetic operators which are analogous to natural genetics.

E. Crossover

The crossover operator takes two chromosomes, separates them at a random site in both chromosomes and then swaps the tails of the two chromosomes, resulting in two new chromosomes which are referred as offspring. If the random site is selected at a single point, then it is called single-point crossover and on the other hand if more than one random site were chosen, then it is called multi-point crossover.

This crossover operator does not introduce any new chromosome into the population, but it simply inter-mixes the existing population of chromosomes to create new chromosomes. This allows the GA, to search for new candidate solutions to solve the problem at hand. The single or two point crossover are the most widely used operator.

F. Mutation

The mutation operator introduces a random change into a gene in the chromosome. The mutation operator provides the ability to introduce new material into the population. Since chromosomes simply intermix with existing chromosomes, mutation provides the chance to expand the solution space.

VI. SIMULATION RESULTS

Simulation of a 15-level multilevel inverter uses four variable dc sources to minimize the harmonics. Four variable dc sources are $V1=81.5$, $V2=81.5$, $V3=81.5$ & $V4=163$. This simulation achieves a speedup of 500x and the execution time range is 20mille seconds. The output voltage of 15 levels multilevel inverter as shown in Fig 5. The solution of this approach is 4.81% of THD by using genetic algorithm as shown in Fig.6.

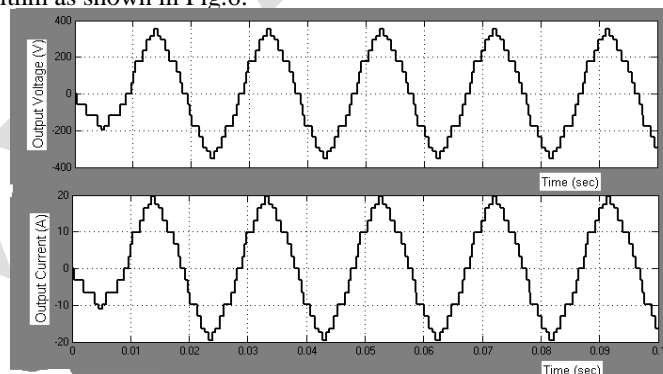

Fig 5: Output of 15 Levels multilevel Inverter

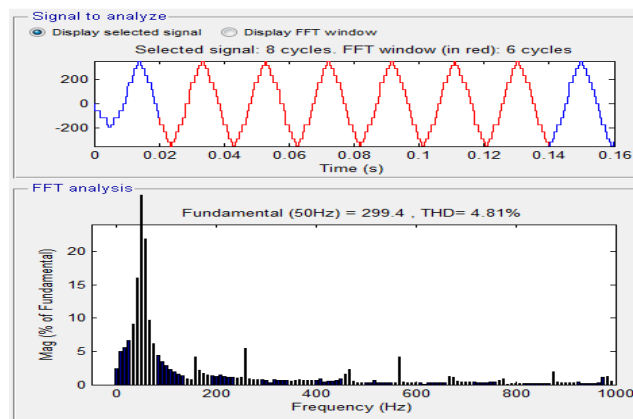

Fig 6: FFT Analysis of 15 Levels Multilevel Inverter

V. CONCLUSION

In this approach, optimization harmonic function in hybrid multilevel inverter using GA was proposed. The proposed system achieved a speedup of 500x and execution time range is 20 milliseconds. Genetic algorithm is used because it speeds up the harmonic minimization function at very narrow time as well as time-consuming process of MATLAB function also very healthy. This work provides a powerful solution for control of multilevel inverter.

REFERENCES

- [1] Vincent Roberge, Mohammed Tarbouchi, and Francis Okou "Strategies to Accelerate Harmonic Minimization in Multilevel Inverters Using a Parallel Genetic Algorithm on Graphical Processing Unit" IEEE transactions on power electronics, vol. 29, no. 10, October 2014.
- [2] Maruthu Pandi Perumal -Devarajan Nanjudapan "Performance Enhancement Of Embedded System Based Multilevel Inverter Using Genetic Algorithm" journal of electrical engineering, vol. 62, no. 4, 2011, 190–198.
- [3] C. Udhaya Shankar, J. Thamizharasi, Rani Thottungal, N. Nithyadevi "Harmonic Reduction In Cascaded Multilevel Inverter With Reduced Number Of Switches Using Genetic Algorithms" international journal of advances in engineering & technology, march 2012.
- [4] J. Baskaran, S. Thamizharasan, R. Rajtilak "GA Based Optimization and Critical Evaluation SHE Methods for Three-level Inverter" International Journal of Soft Computing and Engineering (IJSCE) ISSN: 2231-2307, Volume-2, Issue-3, July 2012.
- [5] Darshan Kumar, Dr. Swapnajit Pattnaik, Mrs. Varsha Singh "Genetic Algorithm Based Approach for Optimization of Conducting Angles in Cascaded Multilevel Inverter" International Journal of Engineering Research and Applications (IJERA) ISSN: 2248-9622 www.ijera.com Vol. 2, Issue 3, May-Jun 2012, pp.2389-2395.
- [6] Chiranjit Sarkar, Soumyasanta Saha, Pradip Kumar Saha, Goutam Kumar Panda "Selective Harmonics Elimination Of Cascaded Multilevel Inverter Using Genetic Algorithm" International Journal of Advanced Research in Electronics and Communication Engineering (IJARECE) Volume 2, Issue 12, December- 2013.
- [7] Yu Liu, Student Member, IEEE, Hoon Hong, and Alex Q. Huang "Real-Time Calculation of Switching Angles Minimizing THD for Multilevel Inverters With Step Modulation" IEEE transactions on industrial electronics, vol. 56, no. 2, february 2009.
- [8] Wang ZhiTeng Zhang Hong Jun Huang Ying Cheng Kai Wu Tianyi "Fire Distribution Optimization Based On Quantum Immune Genetic Algorithm" 2011 International Conference of Information Technology, Computer Engineering and Management Sciences.
- [9] XiongJie, Guan Wei, Zheng bin, He Shuyan, Yin Tingting "Coordinated Optimization of Community Shuttle Timetable Joint for Metros Based on Genetic Algorithm" 2013 Third International Conference on Intelligent System Design and Engineering Applications.
- [10] Vishal Verma, Member, IEEE, and Bhim Singh, Fellow, IEEE "Genetic Algorithm-Based Design of Passive Filters for Offshore Applications" IEEE transactions on industry applications, vol. 46, no. 4, july/august 2010.
- [11] Rajasekaran Rajamoorthy and Ramasamy Bharanikumar, *Performance Analysis of Dual Fed Induction Generator (DFIG) during Grid Fault and LVRT Improvement using STATCOM*, International Journal of Applied Engineering Research 2015