



COLOUR BASED IMAGE REGISTRATION AND AUTHENTICATION USING TOUCH SCREEN

M.Sudarmani

Final year/ECE

*AVS Engineering College,
Salem, India*

sudarmanis027@gmail.com

R.Sriram

Final year/ ECE

*AVS Engineering College,
Salem, India*

sri8302@gmail.com

N.Naveen Kumar

Final year/ECE

*AVS Engineering College,
Salem, India*

naveennandha94@gmail.com

P.Karthick

Final year/ECE

*AVS Engineering College,
Salem, India*

karthickrockshan@gmail.com

P.Dhivya

Assistant Professor/ECE

*AVS Engineering College,
Salem, India*

pdhivyavlsi@gmail.com

ABSTRACT-People need more security to protect their resources like money, documents, jewels etc. but they cannot often to go and use bank lockers every day. So they need a security system in their home to protect those resources. Password that uses text or string of characters such as their names, date of birth are more vulnerable to guess and can be easily cracked. They cannot go for bio-metrics too, as they are costly for middle class people. Our project deals with the processing of colour based passwords to give as pattern for their security reasons, which can be defined by them. This paper gives us the exposure about how to efficiently make use of the touch screen technology to interface with the appliances in our practical life. Using a touch interface can effectively increase operator accuracy, reduce training time, and improve overall operational efficiencies, thus keeping costs down, a properly designed touch interface can improve each operator's accuracy. This paper will conclude that our project will provide security system for ordinary people and illiterates.

I.INTRODUCTION

Passwords based on text are not secure for many applications that provide security and they also have major disadvantages too. As said before, these passwords are very easy to guess and can be easily cracked. Our system can be classified under the simple authentication process that also includes the illiterates to access them too. In this paper we have used NUVOTON micro controller that has CORTEX M0 processor, which is very much useful in these types of applications. As by using colours, it is easy for the person who have poor eye sight can also have access to the system that we have designed. This system uses a touch screen in which the user is able to touch the screen to choose the colour pattern. A regulated power supply is also used in the circuit to provide voltage and current to the dc motor that is used to open the latch of the safe locker. In this we have different sections; the first section is about the block diagram of the system and second section deals with the hardware components and their interconnections.

II.EXISTING SYSTEM

Now days, we use passwords based on texts. These text based passwords are used in many online logins such as Gmail, face book, twitter etc. The biometrics system also being used for protecting a large amount of money, important documents etc, but it makes costlier to the user.

III. PROPOSED SYSTEM

The disadvantage of the existing system is that, these passwords are more vulnerable as they are easy to crack and guess. The Biometrics that is being used in the security systems is more costly that ordinary people cannot afford it. Our proposed system mainly concentrated on the easy accessing of security system for ordinary people and also illiterates.

1. BLOCK DIAGRAM

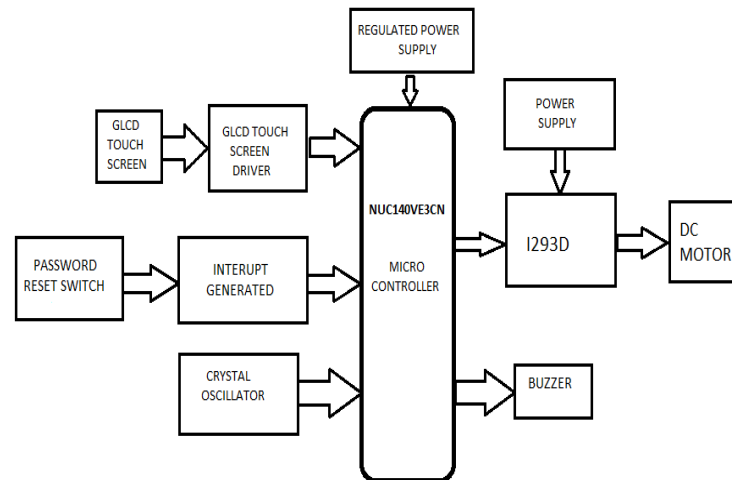

Fig 1.1 Block diagram of registration

the colour based

2. HARDWARE DESCRIPTION

The block diagram consists of

- Regulated power supply
- Micro controller
- GLCD touch screen
- L293D

2.1. Regulated Power Supply:

This regulated power supply consists of a step down transformer that is used to step down the voltage and current for the same power that can be used for the small boards that work at the voltage of 5v. A rectifier that is used in the circuit is used to convert the ac voltage to dc voltage. The rectifiers are mostly diodes connected as bridge rectifiers.

2.2. Micro Controller:

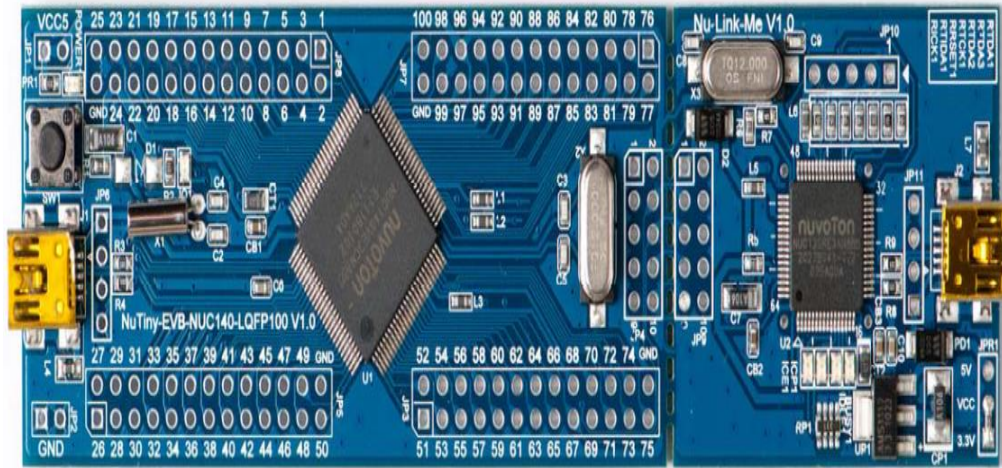

Fig 2.1. Nuvoton controller NUC140VE3CCN

The micro controller that is used in the system is nuvoton controller NUC140VE3CN. This controller is inbuilt with the ARM processor series of CORTEX M0 processor. nuvotonmicro controller consists of 32 bits and it is used in our project.

Power Setting

- USB port J1 is used in NuTiny-EVB-NUC140
- VCC5 Voltage connector JP1 is used in NuTiny-EVB-NUC140
- USB port J2 used in Nu-Link-Me
- JPR1 is used to select either 5V or 3V for System power Consumptions. Debug Connector.

- JP4 connector in target board is used for connecting Nuvoton ICE adaptor
- JP9: Connector in ICE adaptor (Nu-Link-Me) for connecting with a target board (for example NuTiny-EVB-NUC140)

USB Connector

- J1 USB port Connector is in NuTiny-EVB-100 **for application use**
- J2 USB port Connector in Nu-Link-Me is to connect a PC USB port

Extended Connector

- JP3, JP5, JP7 and JP8: Show all chip pins in NuTiny-EVB-NUC140

Reset Button

- SW1: Reset button in NuTiny-EVB-NUC140

Power Connector

- JP1: VCC connector in NuTiny-EVB-NUC140
- JP2: GND connector in NuTiny-EVB-NUC140

2.3. L293D Regulator:

The Device is a monolithic integrated high voltage, high current four channel driver is designed to accept standard Transistor- Transistor logic levels and drive inductive loads and switching power transistors. To use as two bridges each channels is provided with an enable input. A separate input supply is provided for the logic, to operate at a lower voltage and clamp diodes are used. This device is suitable for AN applications Up to 5 kHz frequencies. The L293D is 16 pins which is dual in line package which has 4 center pins connected together and used as ground.

The L293DD is 20 pins which is dual in line package which has 8 center pins connected together and used as ground. The following is the features of the L293D:

- 600mA output current capability per channel,
- 1.2A maximum output current is produced,
- Over temperature protection,
- logical "0" input voltage up to 1.5v,

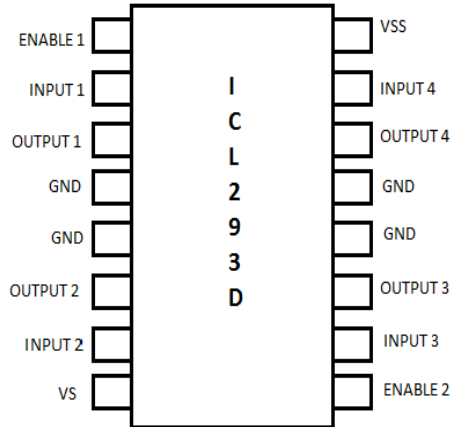

Fig 2.2 Pin Diagram Of L293D With 16 Pins

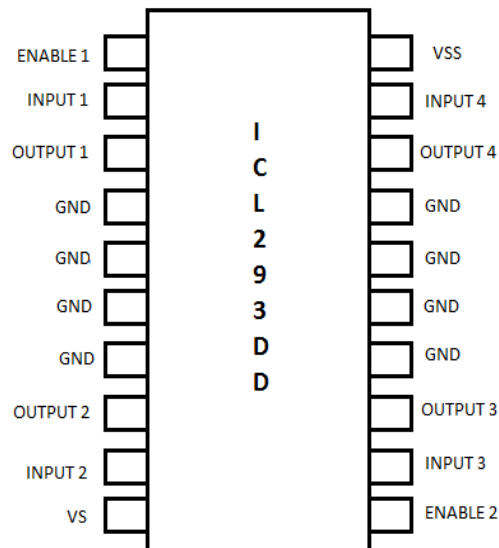

Fig 2.3. Pin Diagram Of L293DD With 20 Pins.

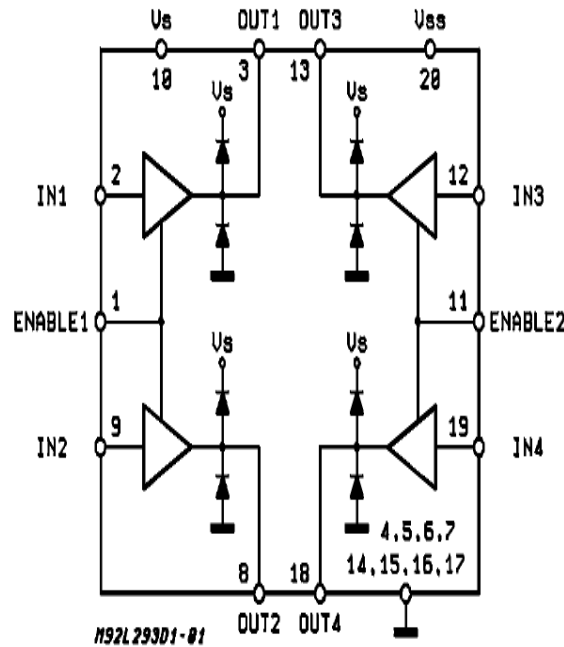

Fig 2.4. Circuit Diagram Of L293D and L293DD Chip

In the circuit diagram there are four operational amplifiers are used. The chip has two enable inputs, four inputs, four outputs, eight ground pins and two pins for power supply. One for the V_{ss} and the other for the V_s . enable is used to select the operational amplifier, input and output that is to be obtained.

Every chip has its own description of pin assignment. The L293d also have the same type of circuit diagram with four pins connected to the ground.

2.4. GLCD Touch Screen (ILI9341):

There are many types of touch screens are available and are listed below,

- Resistive
- Capacitive
- Surface capacitive
- Surface acoustic wave
- Infrared
- Strain gauge

ILI9341 touch screen is a resistive type touch screen. ILI9341 is a 262,144-color single-chip SOC driver for a Thin Film Transistor liquid crystal display with resolution of 240x320 pixels, consists of a 720-channel source driver, a 320-channel gate driver, 172,800 bytes GRAM for graphic display data of 240x320 pixels, and power supply circuit.

ILI9341 supports 16 bit data bus Micro Controller Unit interface in parallel, 16 bit data bus RGB interface and 3-/4-line serial peripheral interface (SPI).

ILI9341 can operate with 1.65V ~ 3.3V I/O interface voltage and a voltage follower circuit is used to generate voltage levels to operate an LCD. ILI9341 supports full color, 8-color display mode and sleep mode for precise power control by software and these features make the ILI9341 an ideal LCD driver for medium or small size portable products such as digital cellular phones, smart phone, MP3 and PMP where long battery life is a major concern.

In this touch screen four wires are used in order to measure the voltage drop at the point we touch. It consists of two layers coated uniformly with transparent material and air gap between them. Two sets of electrodes are placed along the edges of the touch screen.

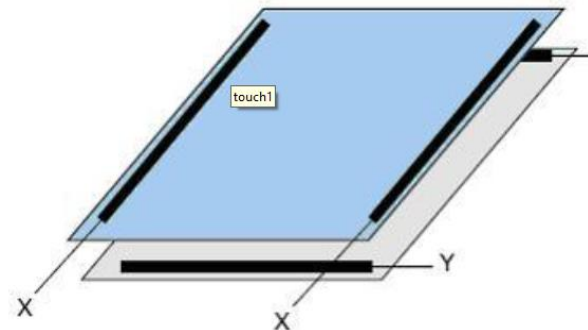

Fig 2.5. Axis diagram for touch screen

When a touch is measured on the touch screen, voltage will be applied across the Y-axis and there is a voltage drop in the point. It is measured by the X-axis electrodes and the coordinates can be sent to the driver circuit, where it reads the data.

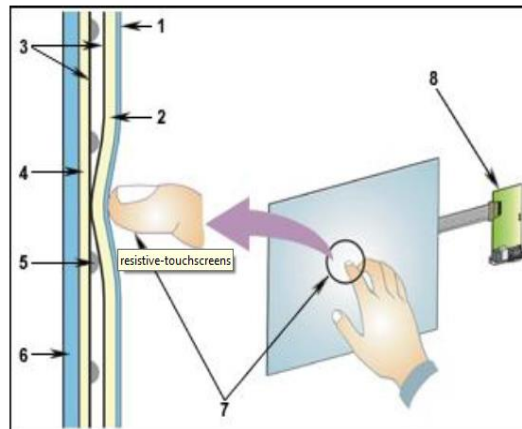

Fig 2.6. Principle working of touch screen

The following are the features of ILI9341:

- Display resolution: [240xRGB](H) x 320(V)
- A-TFT LCD driver with on-chip full display RAM: 172,800 bytes
- Full color mode (Idle mode OFF): 262K-color (selectable color depth mode by software)
- Reduce color mode (Idle mode ON): 8-color.

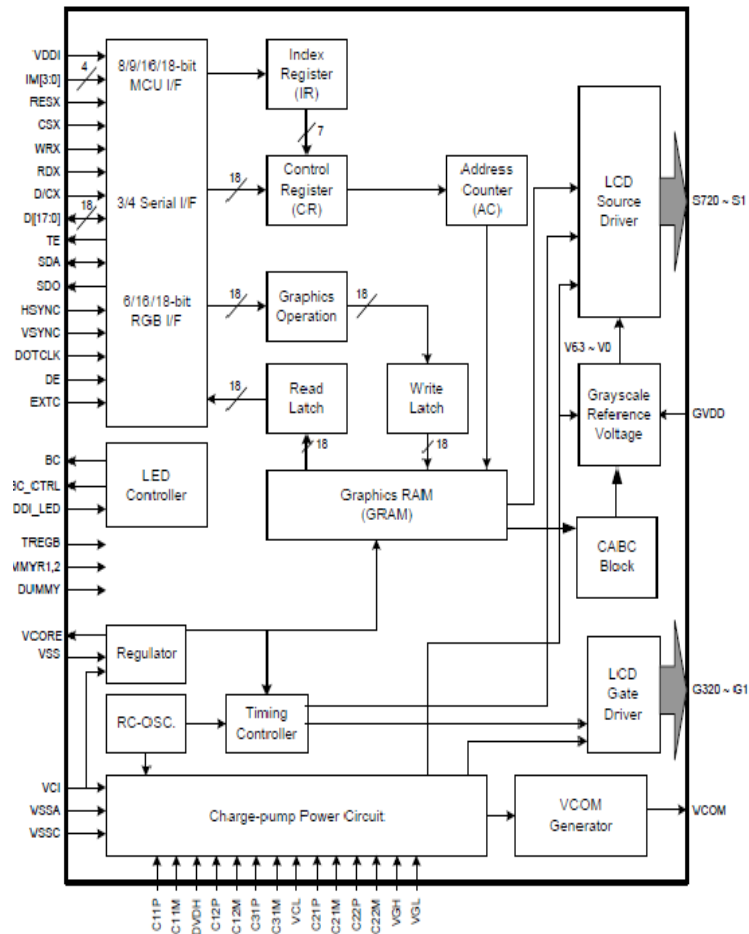

Fig2.7. Block Diagram of Touch Screen Driver

2.4.1 MCU System Interface

ILI9341 provides four kinds of MCU system interface with 8080- /8080 I - II series parallel interface and 3-/4-line serial interface. The selections of the given interfaces are done by external IM [3:0] pins.

2.4.2 Parallel RGB Interface

ILI9341 also supports the RGB interface for displaying a moving picture. When the RGB interface is selected, Display operation is synchronized with externally signals, VSYNC, HSYNC, and DOTCLK and input display data is written in synchronization with these signals according to the polarity of enable signal (DE).

2.4.3 Graphic RAM (GRAM)

GRAM is a graphic RAM to store display data. GRAM size is 172,800 bytes with 18 bits per pixel for a Maximum 240(RGB) x320 dot graphic display.

2.4.4 Grayscale Voltage Generating Circuit

Grayscale voltage generating circuit generates a liquid crystal drive voltage, which corresponds to grayscale level set in the gamma correction register. ILI9341 can display maximum 262,144 colors.

2.4.5 Power Supply Circuit

The LCD drive power supply circuit produces the various voltage levels such as GVDD, VGH, VGL and VCOM for driving TFT LCD panel.

2.4.6 Timing controller

The timing controller produces all the timing signals for display and GRAM access.

2.4.7 Oscillator

IL19341 incorporates RC oscillator circuit which gives stable output frequency for operation.

2.4.8 Panel Driver Circuit

Liquid crystal display consists of 720-output source driver (S1~S720), 320-output gate driver (G1~G320), and VCOM signal.

3. SOFTWARE IMPLEMENTED

We have used KEIL C software. KEIL provides a broad range of development tools like ANSI(American National Standard Institute) c compiler, macro assemblers, debuggers and IDE(Integrated Development Environment), library managers, real time operating system and evaluation boards for Intel 8051, Intel MCS-251(Micro Control System),ARM(Advanced RISC Machine) processors.

By using KEIL software it is possible to compile Embedded c in any environment. It is easy for compiling and debugging the programs.

4. OUTPUT RESULTS

We have given the code and successfully received the following output.

- Initially the touch screen asks for the colour pattern.
- The screen displays three colours red, blue and green.
- The screen also shows the current status of the safe locker if either it is opened or closed.



Fig3.1. Initial Display of Touch Screen In Idle State

- If the colour pattern is give as red, blue and green, then the password matches and the controller makes the dc motor to open the latch of the safe locker.
- In case if the user forgets his pattern then he is provided with a reset button which will generate an interrupt.
- This interrupt program will ask for his favorite colour.
- If the user provides valid colour then the system will display the pattern otherwise, the buzzer will go on.



Fig3.2.Unlocking The door After Giving Valid Sequence

IV.CONCLUSION

The Paper “Colour based image registration and authentication using touch screen” provides security system. This is user friendly device and password secured with colours so that it helps us to remember our passwords easily even for illiterates. It can operate at anywhere and it occupies less space. It should be affordable to every person. Image password is more secure than text based password. It should be Less vulnerable by attacker. This system can be used in bank locker system and home security system and provides high security to the peoples.

V.REFERENCE

- [1] Prafulla, choudhary, savita, poonam, “*image based password authentication*”-IJARCSSE, Vol.5, Issue2, Feb 2015.
- [2] YashInaniya, NareshKumari and UrvashiLuthra “*Home Automation System Using Capacitive Touch screen*”-IJERA, Vol. 4, Issue 6(Version 2), June 2014, pp.101-103
- [3] Pranavagarwal,prakharsinha, neelvora “*face recognition based door lock system using open cv with remote access*”-IJERA, Vol.4, Issue 4(version 6), April 2014, pp.52-57
- [4] Abhijeet S. Kapse¹, Sunil B. Somani² “*Arm as a Touch-Screen*”-IJERA, Vol. 4, Issue 2(Version1), February 2014, pp.725-728.
- [5] z.zheng, x.liu, l.yin “*A hybrid password authentication scheme based on shape and text*” journal of computers, vol.5, no.5 may 2010.
- [6] ALSULAIMAN,F.A and EL SADDIK, “*three dimensional password for more secure authentication*”, vol.57, pp.1929-1938, April 2008.
- [7] Vaughan Nichols, S.J., “*New Interfaces at the Touch of a Fingertip*,” IEEE Computer, Vol.40, No.8, pp.12-15, August 2007.
- [8] Brewster, S.A., Chohan, F., and Brown, L., “*Tactile Feedback for Mobile Interactions*,” ACM CHI2007 Proceedings, pp.159-162, 2007.
- [9] M.H Sheriff “*Intelligent homes: A new Challenge in telecommunications standardization*”, Communications Magazine, IEEE, vol. 40, no. 1, pp.8 2002
- [10] R.A Quinnell, and Richards “*TOUCHSCREEN TECHNOLOGY*”, EDN, NOV 2000.

V.AUTHOR'S BIOGRAPHY



Dhivya.P⁵ is from Salem, Tamilnadu and born on 25th sep 1988 completed M.E. in ECE with specialization(VLSI design)from Paavai engineering college affiliated by Anna university in 2012.She has completed B.E. in ECE from Vivekananda institute of engineering and technology affiliated by Anna university in 2010.Currently she is working as an assistant professor in ECE department at AVS engineering college, Salem from 2012.Her area of research interest include embedded systems,networks,digital image processing and VLSI designing. She is lifetime membership of IETE and IE.

Karthick.P⁴ is from Salem, Tamilnadu and born on 7th June 1995 pursuing B.E. in ECE from AVS Engineering College affiliated by Anna university, Chennai. His area of interest is in Computer networks.

Naveen kumar.N³ is from Salem, Tamilnadu and born on 5th November 1994 pursuing B.E. in ECE from AVS Engineering College affiliated by Anna university, Chennai. His area of interest is in Wireless communication.

Sriram.R² is from Salem, Tamilnadu and born on 23rd may 1995 pursuing B.E. in ECE from AVS Engineering College affiliated by AnnaUniversity, Chennai. His area of interest is in Digital Image Processing.

Sudarmani.M¹is from Salem, Tamilnadu and born on 9thJanuary 1995 pursuing B.E. in ECE from AVS Engineering College affiliated by Anna university, Chennai. His area of interest is in VLSI Design.