



THEFT DETECTION SYSTEM FOR ELECTRICITY USING GSM MODEM

Sharmila.L
lithusharmi@gmail.com
Department of ECE,
AVS Engineering College,
Salem-636003.

Sharmila.D²
sharmilasharmi@mail.com
Department of ECE,
AVS Engineering College,
Salem-636003.

Priyadharshini.S³
Priyaravi1000@gmail.com
Department of ECE,
AVS Engineering College,
Salem-636003.

Prof.Nirmala.G⁴
Department of ECE,
AVS Engineering College,
Salem-636003.

ABSTRACT

Electrical energy is very important for day to day life .wherever the Electricity is needed more; the power theft is also increased. Electricity theft, which arises due to population and also wastage of power. The usage of power is more in industries compare to houses. Objective of this project is to design a system in order to avoid the inconvenience for the users from theft bill by using GSM module. In this system the GSM MODEM is used for detect the theft while it's happen. The sensor is used to sense where will be the theft occur. The sensing information is intimated to the consumer office through the sensors in the form of message signal or a voice message. So the illegal power usage of power consumption can be avoided. The load sharing is as method, used to share the electricity power for all the users in a particular area. The load sharing circuit is connected to each and every pole in the transmission line. It can receive the incoming power from the load and it delivers the power to the consumer for their need. If any drastic change in the power usage, the Real Time Clock (RTC) is used to gives the information about the usage of additional power usage. So it is help to detect the theft when and where it happens. The entire system is for detect and avoid the illegal usage of power. In order to integrate the various systems together we must first properly understand the working of the entire system. A brief study is alone on the components and the technology which we are going to use in our project.

KEYWORDS: *Electricity theft, GSM MODEM, Sensors, Load sharing application.*

1. INTRODUCTION

Electricity theft takes place in a different form, with the support of people from different parts of life. It is needed to be protected for sufficient power delivery to the consumer because electricity is necessary for domestic and industrial activity. Power wastage is one of the typical reason for the power theft, why because certain amount of power is wasted then the necessity of electricity leads to more. The illegal usage tends to some defects also. Not only in the headline cables but also in the underground cables the power is theft.

To overcome this GSM technology is used. By using GSM MODEM theft is prevented while it happens. GSM specification supports the longest distance in practical use of around 35 kilometers. GSM Circuit is connected between the Transformer and Distributor.



Fig1:Basic module for Transmission system.

EB Meter is used to measure readings from a pole and distributor. It is monitored by Signal Conditioning Unit (SCU). Relay is act as a switch, whenever the power level across the peak or theft occurs it disables the connection. Then the sensor detects and passes the information to the GSM Modem. Then it is switch over to consumer office via voice signal. So the theft can be prevented and the power consuming is also saved.

2. RELATED WORK

The related work compared with

[1].S.Amin,G.A.Schwartz, the problem of Electricity theft detection is formulated as a game between the electricity thief and electric utility. These methods may present a low cost and reasonable, though not optimal, solution for reducing energy theft. [2].J.Nagi,K.S.Yap,the average daily consumptions of customers over a two-year period were calculated and the long term trend in energy consumption was used to detect fraudulent customers.[3].S.Depuru,L.Wang,Support Vector Machine(SVM) was used to approximate the consumption pattern of customers based on 96 readings of smart meters in AMI for each day. The classifier was trained using historical data of normal and theft samples. [4] H.G.Rodney, this paper presents of design and development of Automatic meter reading(AMR) system. AMR system is a boom for remote monitoring and control domestic energy meter.[5] M.V.Ramesh,this design incorporates effective solutions for problems faced by India's electricity distribution system such as power theft and transmission line fault.[6] ZHOU Wei, electricity-stealing prevention became a big problem to the electricity board. Which is based on some kind of electricity-stealing and actual demand of power is by prevention of stealing electricity, realizes the behavior of electricity-stealing with remote monitoring system. [7] , SVM was used to approximate the consumption pattern of customers based on 96 readings of smart meters in AMI for each day. The classifier was trained using historical data of normal and theft samples. New samples were classified based on some rules as well as the SVM results. In [8], a neural network model was incorporated to estimate SVM parameters in order to reduce the training time of the classifier, and a data encoding method. [8] was proposed to improve the efficiency and speed of the classifier. Their method, however, is only effective in detecting energy theft attacks that result in zero usage reports, since in one step of the encoding procedure the metering data is converted into binary values. Therefore, the proposed classification Technique cannot detect a wide range of attack types. [9], an improved encoding technique was proposed and both SVM and a rule engine-based algorithm were applied on encoded data to improve the classification accuracy. Portion so the algorithms were parallelized to reduce the detection time. Still the algorithm suffers from the common short comings of classification-based methods as we described in detail. The database used for performance evaluation is not publicly available and the authors did not explain how they obtained theft samples for all customers or what percentages of the training and testing data were theft patterns. On the other hand, in this paper we focus on addressing problems associated with classification-based techniques such as imbalanced data, contamination attacks and dynamic property of consumption patterns to improve

the detection accuracy. We also argue that detection time might not be as crucial as other factors like FPR or implementation cost of the ETDS.

3. PROPOSED METHOD

In this, electricity board supplies the amount of power which is measured by the EB meter. Theft is happen in transmission lines are monitored by Signal Conditioning Unit(SCU) & also electric signals are converted into control signals. It is passing through PIC microcontroller. Real Time Clock(RTC) gives the information about power level is abruptly changing. Relay is act as a switch. Whenever the power level across the peak, then it disable the connection. GSM detects theft signal & the information is passing to EB consumer office via voice signal.

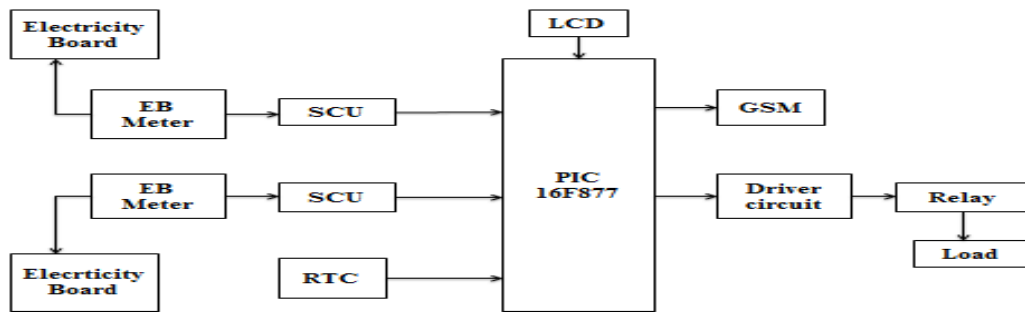

Fig2: Block diagram of theft detection system.

3.1 EB Meter

It is a Power Measurement device. That measures the amount of electric energy consumed by electrically powered device. It has two parts Transducer -converts the power in to electrical energy. Counter-display the readings. Electric current passed through meter, the disk rotates to measure the exact amount of kilowatts-hour used.



Fig 3: Module of EB meter

3.2 PIC 16F877

Peripheral interface controller (PIC) is a family of modified Harvard architecture microcontroller made by microchip technology. It is a 16 bit controller. It consists of high performance & low cost. The architecture of this controller is RISC. In this system it receives the control signals from SCU. It also regulates the power from RTC and also the regulated readings are displayed by Liquid Crystal Display (LCD). Both the data are controlled by PIC.

3.3 SCU

It is abbreviated as signal conditioning unit. It is used to manipulating the analog signal which is used in analog to digital converter. In our field it is common to have a sensor. It is used to make the sensor output stable for processing after conditioning. The electrical signals are converted into control signals and it is passed through PIC.

3.4 RTC

RTC is represented as a Real Time Clock. It gives the information about, when the power level is abruptly changing. Control signals from the PIC are passing through driver circuit. The driver circuit controls the LCD and regulates the current flowing throughout the circuit.



Fig 4: Module of RTC

3.5 RELAY

A relay is an electrically operated switch. Current flowing through the coil of the relay creates a magnetic field which attracts a lever and changes the switch contacts. The coil current can be on or off so relays have two switch positions and they are doublethrow (changeover) switches. A relay allows one circuit to switch a second circuit which can be completely separate from the first. For example a low voltage battery circuit can use a relay to switch a 230V AC mains circuit. There is no electrical connection inside the relay between the two circuits; the link is magnetically and mechanically connected. Here Relay is act as a switch, whenever the power level across the peak or theft occurs it disables the connection. Then the sensor detects and passes the information to the GSM Modem.

3.6 LCD DISPLAY

The 16x2 LCD display is used in this system. There is no theft occurs in transmission line, it display readings. If any theft occurs it display like “THEFT IS DETECTED”.

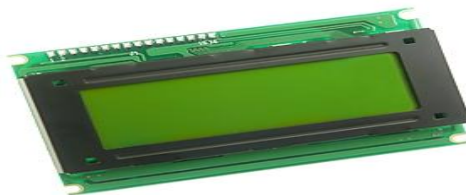

Fig 5: Module of LCD display

3.7 GSM MODEM

A GSM modem is a type of modem which accepts a SIM card, and operates over a subscription to mobile operator, just like a mobile phone. From the mobile operator specification, a GSM modem looks just like a mobile phone. It acts as the sensing circuit. If theft is detected it will send the information via voice signal to EB consumer office. Then the power supply is terminated by using Relay.

4. EXPERIMENTAL RESULT

The experimental result shows that the comparison between the overall usage of power and the illegal usage of power. Where the normal usage of power is increased depends on the given load. While theft occurs, the value of a load must be a change depends on the usage of power.

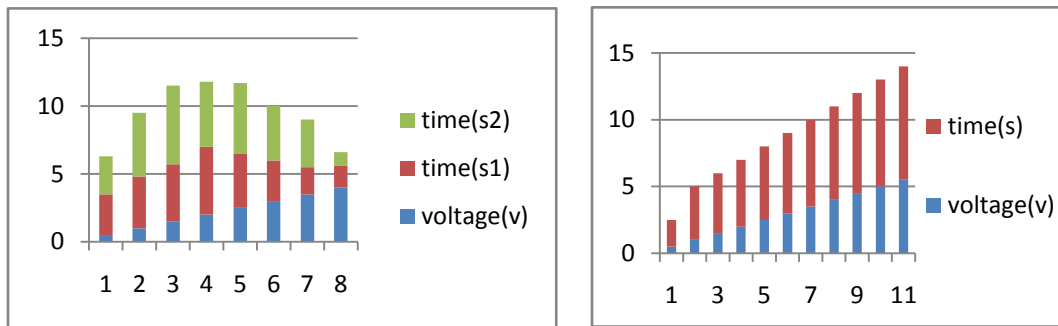

Fig 6: Representation of power theft and the overall usage of power

Table 1 shows that Power is used for house hold appliances is between 3000w to 6500watts. Total loss of power from tower is 22.7%. Here we are inserting a table which contains approximated values of the theft power.

Table 1: Minimum power usage and power theft

| S.NO | HOME APPLIANCES | MINIMUM POWER USAGE IN WATTS | APPROXIMATE VALUE OF THEFT POWER |
|------|--------------------------|------------------------------|----------------------------------|
| 1. | TV | 23W | 20.012W |
| 2. | FAN | 25W | 19.994W |
| 3. | TUBE LIGHT | 40W | 35.002W |
| 4. | UNINTERRUPT POWER SUPPLY | 144W | 145.102W |



5. CONCLUSION

This system reduces the manual work for theft detection using GSM. The voice signal is used to convey the information about theft. To resolve the problem the government govern some techniques that yet to be implemented. Load sharing application is an important feature that we are implementing in this project. It is also a key to reduce a illegal usage of power. In future work, depends on the user, usage of power is limited to everyone. So the illegal consumption of power will be terminated. And also we are trying to save the power.

6. ACKNOWLEDEMENT

We thank everyone who supported us for preparing this paper. We dedicate our honor and Respectedness to professors for their supports and suggestions.

7. REFERENCE

- [1]. S.Amin ,G.Schwartz and H. Tembine”, incentives and security in electricity distribution networks” in decision and game theory for security. Berlin, Germany:Spinger-verlag,2012.
- [2]. J.Nagi , K. S. Yap, K. Sieh, S. Ahmed, and M. Mohamad, “Non technical loss detection for metered customers in power utility using support vector machines,” *IEEE Trans. Power Del.*, Apr. 2010.
- [3]. A. A. Cardenas, S. Amin, G. Schwartz, R. Dong, and S. Sastry , “A game theory model for electricity theft detection and privacy-aware control in AMI systems,” in *Proc. IEEE Allerton Conf. Commun. Control Comput.*, Monticello, IL, USA, 2012.
- [4]. H.G. Rodney, this paper presents of design and development of Automatic meter reading (AMR) system. AMR system is a boom for remote monitoring and control domestic energy meter.
- [5]. M.V. Ramesh, This design incorporates effective solutions for problems faced by India’s electricity distribution system such as power theft and transmission line fault.
- [6]. ZHOU Wei, ZHU Rui-de, WANG Jin-quan. GSM based monitoring and control system against electricity stealing. Electric Power Automation Equipment, 2004.
- [7]. S. Depuru, L. Wang, V. Devabhaktuni, and P. Nelapati, “A hybrid neural network model and encoding technique for enhanced classification of energy consumption data,” in *Proc. IEEE Power Energy Soc. Gen. Meeting*, San Diego, CA, USA, 2011, pp. 1–8.
- [8]. S. Depuru, L. Wang, V. Devabhaktuni, and R. C. Green, “High performance computing for detection of electricity theft,” *Int. J. Elect. Power Energy Syst.*, vol. 47, pp. 21–30, May 2013.
- [9]. M. D. Martino, F. Decia, J. Molinelli, and A. Fernández, “Improving electric fraud detection using class imbalance strategies,” in *Proc. ICPRAM*, vol. 2. Vilamoura, Portugal, 2012, pp. 135–141.
- [10]. K. Hempstalk, E. Frank, and I. H. Witten, “One-class classification by combining density and class probability estimation,” in *Machine Learning and Knowledge Discovery in Databases*. Berlin, Germany: Springer-Verlag, 2008, pp. 505–519.
- [11]. A. A. Cárdenas, S. Amin, G. Schwartz, R. Dong, and S. Sastry, “A game theory model for electricity theft detection and privacy-aware control in AMI systems,” in *Proc. IEEE Allerton Conf. Commun. Control Comput.*, Monticello, IL, USA, 2012, pp. 1830–1837.
- [12]. C. J. C. Burges, “A tutorial on support vector machines for pattern recognition,” *Data Min. Knowl. Disc.*, vol. 2, no. 2, pp. 121–167, 1998.
- [13]. *Irish Social Science Data Archive*. [Online]. Available: <http://www.ucd.ie/issda/data/commissionforenergyregulationcer/>
- [14]. J. J. Culwell, *Research Study Quantifies Energy Theft Losses*, Meter. Int., Tokai, South Africa, 2001.
- [15]. U. Greveler, B. Justus, and D. Loehr, “Multimedia content identification through smart meter power usage profiles,” in *Proc. 8th Int. Conf. Comput. Privacy Data Protect.*, Brussels, Belgium, 2012, pp. 1–4



8. BIOGRAPHY.



SHARMILA.L was born in Salem, Tamil Nadu in 1994. I am pursuing U.G Degree in Electronics and Communication Engineering, under Anna University, Chennai. My Area of interesting is Digital image processing. Wireless communication and Wireless sensor networks.



SHARMILA.D was born in Salem, Tamil Nadu in 1995. I am pursuing her U.G Degree in Electronics and Communication Engineering, under Anna University, Chennai. Digital signal processing, Wireless networks and Digital image processing.



PRIYADHARSHINI.S was born in Salem; Tamil Nadu in 1995.I am pursuing U.G Degree in Electronics and Communication Engineering, under Anna University, Chennai. Signals and systems, Antennas and wave propagation, and embedded systems.



NIRMALA.G was born in Salem, Tamil Nadu in 1989.She was received her P.G Degree in Gnanamani college of technology in 2014. At present she is working as a Assistant Professor in the Department of Electronics and Communication Engineering in AVS engineering college, Salem, Tamil Nadu.