

Talking Glove-A boon for the deaf, dumb and physically challenged

Sruthi Dinesh

Final year mtech student, Digital Electronics, Malabar Institute of Technology
Anjarakkandy, Kerala, India
sruthidinesh11@gmail.com

Abstract— The paper describes an aiding device for the deaf, dumb and physically challenged people. Such people are made to wear gloves fitted with flex sensors whose resistance change with each gesture shown by them. This produces a voltage change and the PIC microcontroller will display the codes corresponding to each gesture on LCD and the sound code is heard via speaker. Also this device helps to control on-off of devices like fan, bulb etc. by means of RF transmitters and receivers. A wireless camera fitted near the door enables image recognition and automatic control of door opening. The system can also send an sms to a prestored mobile number via GSM modem in case of an emergency.

Keywords— Flex sensor, gesture, sign language

I. INTRODUCTION

Deaf and dumb people normally communicate by means of sign-language. This device which converts hand gestures to sound codes and also controls the working of devices will be a big relief for such people, reducing the communication gap between the deaf community and the normal world. It is a low-cost, compact, flexible system and only takes less power to operate.

II. PREVIOUS WORK

Lots of research has been going on in the field of glove-based systems and their applications. Initially, neural networks were used to implement an adaptive interface, called GloveTalkII, which maps hand gestures to control the parameters of a parallel formant speech synthesizer to allow a user to speak with his hands. Thai Finger spelling Sign Language Recognition System (TFRS) receives data from a data glove and a motion tracker, where the data glove provides signals of flexures of each finger and the motion tracker provides signals of positions and orientations. In American Sign Language Interpreter, when the user makes a hand gesture, the values of fingers were checked for 5 times and if they matched, then the microcontroller indicated the gesture as valid and perfect match.

III. BLOCK DIAGRAM

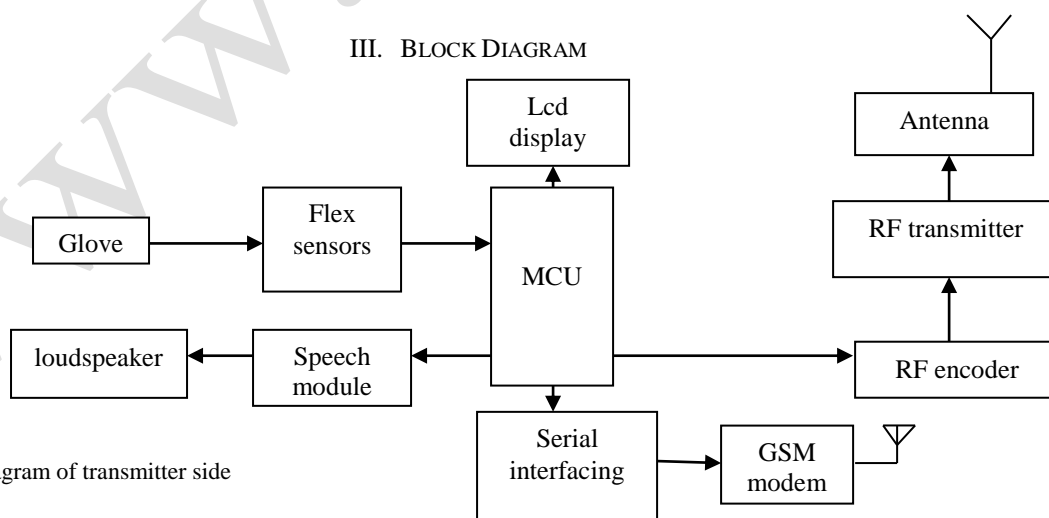

Fig. 1. Block diagram of transmitter side

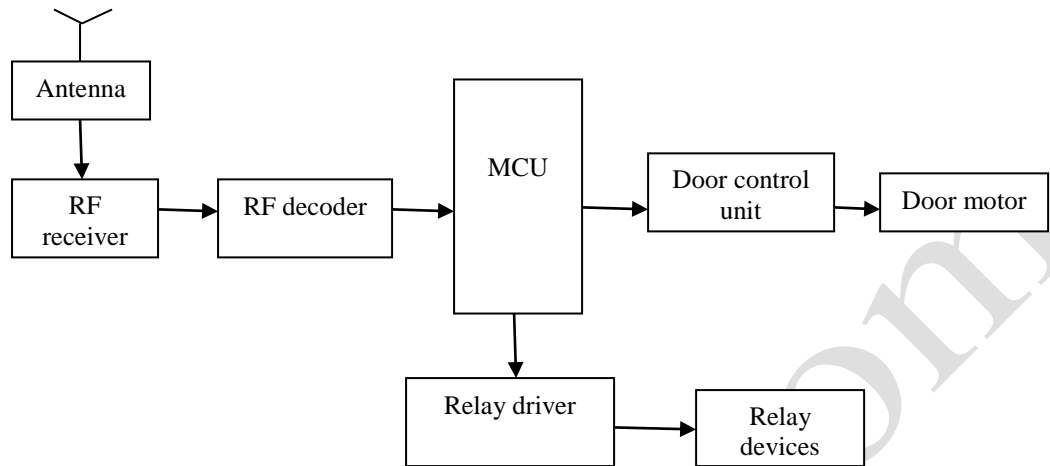

Fig.2. Block diagram of receiver side

Fig.1. shows the block diagram of transmitter side and fig.2. shows the block diagram of receiver side.

A. Flex sensors

Gloves worn by the deaf and dumb people are fitted with flex sensors made of resistive carbon elements. Resistance of these flex sensors change with change in the degree of bending. As they are interfaced to the PIC microcontroller via a voltage divider circuit, the change in resistance produces a corresponding change in analog voltage.

B. PIC 16F877A

The output of flex sensors is given to the PIC input. The inbuilt analog-to-digital converter of PIC 16f877a will convert the analog voltage from flex sensors to digital voltage. The flash memory of PIC is programmed in such a way that there is a code corresponding to each of the digital value generated by the ADC.

C. 16 X 2 LCD

Port D lines of the PIC are connected to data lines of the LCD so that when a gesture is shown, corresponding ASCII codes of letters, numbers or words are sent by the PIC to display them on the LCD module.

D. Speech module and loudspeaker

APR89341 one-time programmable speech IC is used here so that speech codes corresponding to each gesture can be initially recorded and later played back when it gets a trigger signal from the PIC. Port B pins of the PIC are connected to s1 to s8 pins of the PIC which serve as address bits to address the memory location corresponding to each code. Output of speech IC is given to sound amplifier LM386 and is heard via the speaker.

E. GSM modem

The purpose of GSM modem is to send message to the prestored mobile number when the emergency switch is pressed. The modem is interfaced to the PIC via MAX232 IC which can convert between TTL and RS232 voltage levels.

F. RF encoder and transmitter

RF encoder ST3654 receives data input from the PIC as per the gesture and converts it into coded form before giving it to 2.4 Ghz RF transmitter which transmits the signal

G. RF receiver and decoder

2.4 Ghz RF receiver receives the transmitted signal and gives it to RF decoder ST3654 which recovers the original data.

H. PIC 16F873

It is a 28-pin device with program memory capacity of 4 kb which can be programmed to control the operation of devices, camera and door lock.

I. Relays

According to gesture shown, devices connected to the 12 volt relays can be switched on or off. Relays are interfaced to the PIC through a relay driver circuit ULN2803 which is a current amplifier and works on Darlington emitter configuration.

J. Wireless camera

It is fixed near front door, captures images from outside area. Received signal from video receiver is given to the monitor.

K. Door motor

PIC receives data regarding door lock control and initiates opening or closing of the door via motor driver circuit L293D which is an H-bridge circuitry.

IV. WORKING

Flex sensors are attached to gloves which can be easily handled by a deaf or dumb person. There will be change in resistance values and thereby, output voltage of flex sensors corresponding to different gestures. Analog voltage is converted to digital value by in-built ADC of PIC 16f877a. PIC finds the code corresponding to the digital voltage from program stored in its flash memory. The code is displayed on LCD connected to its port D. When speech IC connected to port B gets trigger from PIC, it plays back the voice tags stored in it corresponding to the codeword. The sound code is amplified and heard via the speaker. When emergency situation is indicated by the user through a gesture, PIC sends sms to prestored mobile no. using GSM modem and also reproduces voice tag. PIC operates the devices connected to its relays and also determines the door lock control when user indicates it through a gesture after obtaining the captured camera images on the receiver side.

V. FUTURE WORK

The system can be enhanced to include two or more accelerometers to translate larger gestures. It can be used for remote handling, smooth traffic control, computer-aided design and rehabilitation of trauma-affected patients.

Acknowledgment

I would like to thank our Principal Dr. S .K. Masud Hossain, Head of the Department, Prof. Jacob Zachariah, our co-ordinator Asst. Prof. Sreetha Sreedhar and my guide Asst. Prof. Shruti.K. for their valuable advice and technical assistance.

References

- [1] Laura Dipietro, Angelo M. Sabatini, Senior Member, IEEE, and Paolo Dario, Fellow, IEEE, "A survey of glove-based systems and their applications", IEEE Transactions on Systems, Man and Cybernetics, -Part C: Applications and Reviews, Vol.38, No.4, July 2008
- [2] S.Sidney Fels and Geoffrey E. Hinton, "Glove-TalkII- a neural-network interface which maps gestures to parallel formant speech synthesizer controls, IEEE Transactions on Neural Networks, Vol.9, No.1, January 1998
- [3] Kunal Kadam, Rucha Ganu, Ankita Bhosekar, Prof.S.d.Joshi, "American sign language interpreter", 2012 July, IEEE Fourth International Conference on Technology for Education
- [4] Anbarasi Rajamohan, Hemavathy R., Dhanalakshmi M., "Deaf-mute communication interpreter", International Journal of Scientific Engineering and Technology (ISSN : 2277-1581) Volume 2 Issue 5, pp : 336-341 1 May 2013 IJSET@2013 Page 336
- [5] Syed Faiz Ahmed, Syed Muhammad Baber Ali, Sh. Saqib and Munawwar Qureshi, "Electronic speaking glove for speechless patients: a tongue to a dumb", Proceedings of the 2010, IEEE Conference on Sustainable Utilization and Development in Engineering and Technology
- [6] Neha V. Tavari, Prof. A. V. Deorankar, Dr. P. N. Chatur, "Hand gesture recognition of indian sign language to aid physically impaired people", International Journal of Engineering Research and Applications (IJERA) ISSN: 2248-9622
- [7] Ambika Gujrati, Kartigya Singh, Khushboo, Lovika Soral, Mrs. Ambikapathy, "Hand-talk gloves with flex sensor" International Journal of Engineering Science Invention ISSN ,pp 43-46.