



# POWER CONTROL AND MANAGEMENT IN A HYBRID AC/DC MICROGRID USING DECENTRALIZATION CONTROL SYSTEM

S.Rohini<sup>1</sup>,T.Sasikumar<sup>2</sup>

PG Student [PSE], Dept of Electrical and Electronics,VCEW,Namakkal,TamilNadu,India<sup>1</sup>

Assistant professor, Dept of Electrical and Electronics,VCEW,Namakkal,TamilNadu,India<sup>2</sup>

## ABSTRACT:

Microgrid concept widely for the better interconnection of DGs. Hybrid AC/DC micro grids have been planned for the improved interconnection of different distributed generation systems (DG) to the power grid, and exploiting the prominent features of both ac and dc micro grids. In this project consist of renewable energy utilization for the power management to the grid. To solve the problem of dynamic power control, the concept of decentralization control system for virtual impedance is introduced in this project. The source from the wind and solar is coordinated to the DC bus bar then the amount of required energy is given to the grid the balance energy is stored by the battery and capacitor storage. The local load is supplied from DC microgrid when the local load demand increases the excess power required will be delivered from AC grid through tie-breaker. The power flow control and management issues amongst multiple sources discrete all through both ac and dc micro grids. The paper proposes a decentralized power sharing method in order to eliminate the need for any communication between DGs or micro grids. The concert of the proposed power control strategy is validated for dissimilar operating conditions, by means of simulation in the MATLAB software environment.

**Keywords:** Decentralization control, DG, Hybrid sources, AC/DC Micro grid, Power management

## 1. INTRODUCTION

Distributed power generation from clean and sustainable energy sources near consumers is reshaping the structure of modern power systems. Distributed generators (DGs) and local energy storage systems (ESSs) can be organized into an autonomous micro grid to mitigate the power intermittency of renewable DGs and enhance power quality, efficiency, and reliability for both the utility and consumers. Due to increasing the development of DGs in power system and association the power from Distributed generators by using the grid is the major concern. So micro grid is the accepted concept for the improved interconnection of DGs in to the grid. Equivalent to conventional power system AC micro grid has been proposed. at the present a days we are using renewable energy sources which mostly generated DC power which need a DC link for the grid connection. so it appear the DC micro grid, which increasing the use of modern DC loads for their benefits in terms of efficiency, charge and system that can eliminate the dc-ac , ac-dc power

conversion stages and their power losses. Now a days we are simply depends on power grid which are ac type, which is dominant, but the emerged of DC grid does not replace the AC grid completely. therefore we are interfacing AC and DC micro grid, which are linked by IC. This is the bidirectional ac/dc converter which establish a hybrid ac/dc micro grid. Like other micro grid the hybrid ac/dc micro grid can control in some of these three modes. Grid connected, Islanding mode, Transition mode. Therefore a appropriate control strategy is required to coordinate the operation of dc sources ac sources and IC, which need a quick communication link reliability concern, which uses a decentralized control among which droop control method can be used for which correct power sharing between ac and dc micro grid. Through islanding operation the IC act as a function of supplier to one micro grid at the same time act as load to other micro grid and shares the power demand between accessible sources. a further challenge is that since the generated power in each micro grid is limited the power managing system should be capable to share the power demand between the

existing ac and dc sources. Consequently a individualget tired control method is desired to coordinate the power flows and to cover acceptable power distribution.. By determine the ac micro grid frequency and the dc micro grid voltage and using planned droop quality. The power management policy provides the power position for the IC control to share the power demand between the existing power sources in both ac and dc micro grid. during this control approach, the two micro grids can be treated as a combined micro grid in which the demand load power can be shared between the existing energy sources in this hybrid micro grid. Therefore, the installed power reserve can support the two micro grids commonly and it allows reduced amount of reserve power for each micro grid. The primary input of this project during islanding operation IC plays a vital role to manage the demanded power between ac and dc micro grids. The positive IC power flow which indicates that the excess power in the ac micro grid will be transfer to the dc micro grid.

## 2. EXISTING SYSTEM

In the existing system describes the conventional droop control scheme, to enable both time-scale and power-scale coordination in a distributed micro grid system. Thestate of the artdroop basedcontrolsolutionsusedin dcmicrogrids onlyguaranteestaticpower sharing. The coordinating regulation of a hybrid energy storage system composed of batteries and super capacitors. With an efficient frequency-domain shaping of the virtual output impedances the battery and super capacitor converters are calculated to absorb low-frequency and high-frequency power fluctuations respectively. The target of such a system is coordinating the distributed microgrid terminals. However, these methods cannot be fully migrated into dc micro grids because of the aforementioned special features of the dc system.

## 3. PROPOSED SYSTEM

Hybrid AC/DC microgrids have been planned for the better interconnection of different distributed generation systems (DG) to the power grid, and develop the important features of both ac and dc micro grids. Connecting these micro grids need an interlinking AC/DC converter (IC) with aappropriate power management and control strategy. The power management system should be

capable to share the power demand between the existing AC and dc sources in both micro grids.the power flow control and management issue amongst multiple source dispersed throughout both ac and dc microgrids. The paper proposes a decentralized power sharing technique in order to eliminate the need for any communication between DGs or micro grids. This hybrid micro grid arrangement allows different ac or dc loads and sources to be flexibly located in order to decrease the required power conversionstage and hence the system cost and efficiency.

## 4. BLOCK DIAGRAM

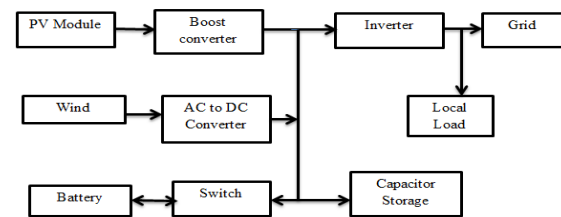

Figure 1. Block diagram

The PV segment connected to DC micro grid through a boost converter similarly connected to a AC grid through inverter. The power generated from wind energy system is connected to a DC microgrid through a AC to DC converter. The battery and capacitor storage are connected to a DC bus bar through a switch can be charged from the DC bus bar. When the load demand increases then the power from the battery and capacitor storage space are delivered to the load. The power from DC microgrid is given to the local load and AC grid through a inverter. The local load is supplied from DC microgrid when the local load demand increases the excess power required will be delivered from AC grid through tie-breaker.

## 5. SYSTEM DESCRIPTION

A simple hybrid ac/dc microgrid is consists of an ac microgrid with conventional distribution generation sources, a dc microgrid with two dc type sources, two microgrids together. Each of these microgrids also includes their individual loads. Besides, during normal grid operation the hybrid microgrid is connected to the main utility grid through the ac microgrid. Basically, the microgrids are thought to operate in grid connected mode. In this

operating condition the dc sources can generate a constant power or can operate in maximum power point for the renewable energy sources.

### 5.1 MODEL of PV ARRAY

The basic structure of PV cell is given below,

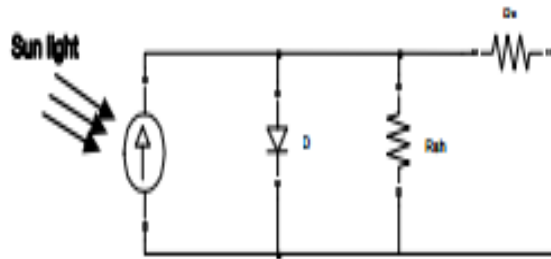

Figure 2: Basic model of PV

$R_s$  = series resistance  
 $R_{sh}$  = shunt resistance

So,

$$I = I_L - I_0 \left[ e^{(q(V+R_s I) / kT)} - 1 \right] - V + R_s I \cdot R_{sh} \quad (1)$$

Here,

$I$  = cell output current,  
 $I_0$  = cell reverse saturation current,  
 $\alpha$  = diode ideality constant,  
 $I_L$  = light generated current .

Open circuit voltage,  
 $V_o = (kT/q) \ln[ I_L / I_0 ]$

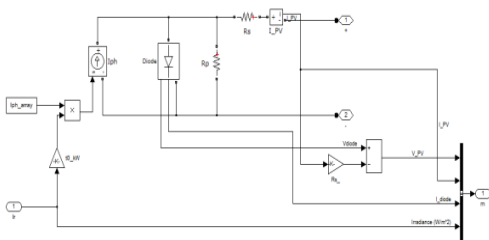

Figure 3. Model of PV module in MATLAB

### 5.2 WIND GENERATION

The wind turbine generator system is the only generator unit in utility network where mechanical stiffness is lower than electrical stiffness or synchronizing torque coefficient. The inertia constants of the wind turbine and generator system have significant effects on the transient stability of

the wind generators and the wind farm. The wind turbine and generator inertia parameters that give best response during transient in the first strategy were used to determine the best shaft stiffness in the second strategy. The simulation results show that high values of the wind turbine and generator inertia parameters could lead to more oscillations.

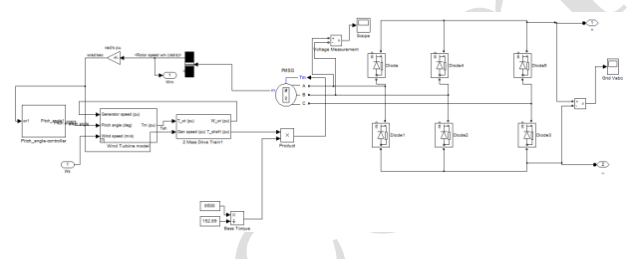

Figure 4 Wind Generation System

### 5.3 CONTROL OF DC-DC INTERLEAVED BOOST CONVERTER

The photovoltaic array power is certainly a non-linear function of the working array voltage and this utility has a maximum power point (MPP) to exacting value of voltage. Therefore, photo voltaic systems are frequently prepared with MPP trackers to facilitate utilize electrical rules to track the MPPs under different environmental conditions.

### 5.4 VOLTAGE SOURCE INVERTER

In order to manage three phase voltage source inverters (VSI), there are two control approach: current control and voltage control. The voltage controlled VSI use the phase angle connecting the inverter output voltage and the grid voltage to manage the power flow. The current controlled voltage source inverter, the active and reactive components of the current add into the grid are controlled by means of pulse width modulation (PWM) techniques. A current controller is less susceptible to voltage phase shifts and to alteration in the grid voltage. Moreover, it is quicker in response. On the other hand, the voltage control is susceptible to little phase errors and large harmonic currents may arise if the grid voltage is distorted. The current controller of three phases VSI necessary part in controlling grid connected inverters.

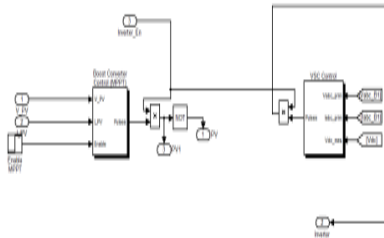

Figure 5 MPPT and voltage source controller

### 5.5 GRID-CONNECTED MODE

While the hybrid ac/dc microgrid is connected to the main utility grid, DG sources in the ac microgrid are expected to either generate a specified real/reactive power, or act as terminal voltage regulator with a specified amount of active power and variable reactive power. On the other hand, the utility grid operates as slack bus to support the difference in the active/reactive power demand and to sustain the microgrid frequency. Similarly, in dc microgrid, DG sources would be controlled to generate a specified active power. However, the utility grid is still responsible for voltage support and power balance. In this mode the renewable energy sources in the microgrid can operate in maximum power point, energy storages can charge and nonrenewable sources can be managed, e.g., for peak shaving purposes, loss reduction or economical goals. In the ac microgrid, DGs could also generate a specified reactive power, regulate terminal voltage or may be used for power quality aims.

### 6. SIMULATION DIAGRAM

Hybrid AC/DC micro grids have been planned for the better interconnection of different distributed generation systems (DG) to the power grid, and exploiting the prominent features of both ac and dc micro grids. Connecting these micro grids requires an interlinking AC/DC converter (IC) with a proper power management and control strategy. The power management system should be able to share the power demand between the existing AC and dc sources in both micro grids.

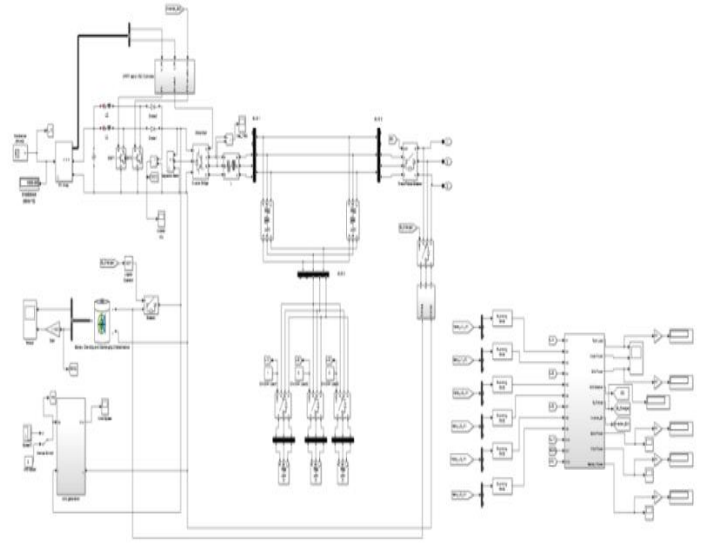

Figure 6 Simulation Diagram.

### 7. SIMULATION RESULTS

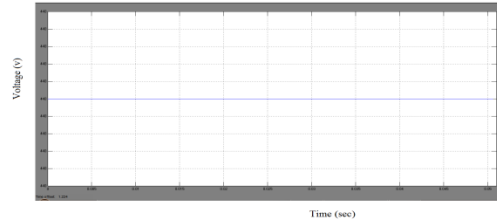

Figure 7 DC To DC Converter Output Voltage

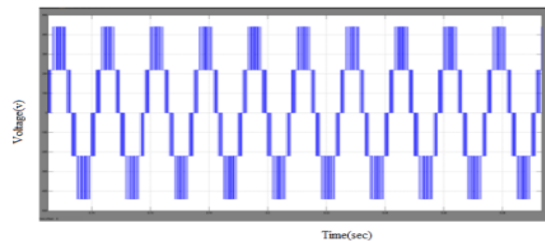

Figure 8 Inverter Voltage

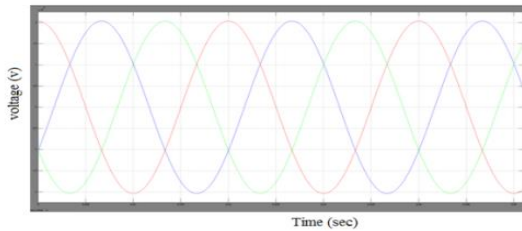

Figure 9 Grid Voltage

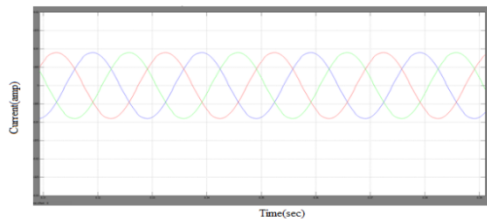

Figure 10 Grid current

## 8. CONCLUSION

This paper proposes a decentralized control strategy based on the two stage modified droop method in dc and ac micro grids. This hybrid micro grid architecture prepares an infrastructure for flexible connection of different ac or dc loads and sources to the grid. This project is designed to the decentralization control of virtual impedance concept for autonomous power management of a ac/dc micro grid. The concept of decentralization control to enable the tie breaker based only on the information extracted from the micro grid. An Exemplary application of the proposed concept is considered for

the hybrid ESS consisting of batteries and capacitor storage. Using the proposed methods makes it possible to decrease the required power conversions stages and hence the system cost and efficiency.

## REFERENCES

1. Y. Chung, W. Liu, D. A. Cartes, E. G. Collins, Jr, and S. Moon, —Control methods of inverter interfaced distributed generators in a micro grid system,|| IEEE Trans. Ind. App., vol. 46, no. 3, pp. 1078–1088, May/Jun. 2010.
2. H. Nikkhajoei and R. H. Lasseter, —Distributed generation interface to the certs micro grid,|| IEEE Trans. Power Del., vol. 24, no. 3, pp. 1598–1608, Jul. 2009.
3. F. Katiraei, M. R. Iravani, A. L. Dimes, and N. D. Hatziargyriou, —Micro grids management: control and operation aspects of micro grids,|| IEEE Power Energy Mag., vol. 6, no. 3, pp. 54–65, May/Jun. 2008.
4. C. K. Sao and P. W. Lehn, —Control and power management of converter fed micro grids,|| IEEE Trans. Power Syst., vol. 23, no. 3, pp. 1088–1098, Aug. 2008.
5. F. Katiraei and M. R. Iravani, —Power management strategies for a micro grid with multiple distributed generation units,|| IEEE Trans. Power Syst., vol. 21, no. 4, pp. 1821–1831, Nov. 2006.