

# Transformer less H6-Bridge Cascaded STATCOM with Star Configuration for Real and Reactive Power Compensation

A.Elakkiya

PG Student [PSE], Dept of Electrical and Electroni.cs,VCEW,  
Namakkal,TamilNadu,India.

E.Shyamaladevi

Assistant professor, Dept of Electrical and Electronics,VCEW  
Namakkal,TamilNadu,India,

**ABSTRACT:** The main aim this project is to design a STATCOM which has the capability of compensating the fault and to overcome the conduction losses faced by the conventional STATCOM with traditional H-Bridge structure. The future control procedures bestow themselves not only to the current loop control but also to the dc capacitor voltage control. The dc capacitor voltage control, overall voltage control is understood by embracing a proportional resonant controller. An Artificial fault is injected for a limited time period duration. Real and reactive power is being maintained for the compensated voltage and current. The simulation process is done in MATLAB 2014 simulation tool.

**Keywords:** STACOM, H6-Bridge, PR Controller.

## 1. INTRODUCTION

FLEXIBLE ac transmission systems (FACTS) are being progressively used in power system to improve the system operation, power transfer ability as well as the power quality of ac system interconnections. As a typical shunt FACTS device, static synchronous compensator (STATCOM) is employed at the point of common connection (PCC) to absorb or inject the necessary reactive power, through which the voltage feature of PCC is upgraded. In recent years, many topologies have been functional to the STATCOM. Among these different types of topology, H-bridge cascaded STATCOM has been broadly recognized in high-power applications for the succeeding advantages: quick response speed, small volume, high efficiency, minimal interface with the supply grid and its individual phase control ability. Associated with a diode-clamped converter or flying capacitor converter, H-bridge cascaded STATCOM can achieve a high number of levels more simply and can be coupled to the grid straight without the bulky transformer. This supports us to ease cost and advance presentation of H-bridge cascaded STATCOM. There are two technical challenges which exist in H-bridge cascaded STATCOM to date. First, the control method for the current loop is an insignificant factor manipulating the compensation performance. However, many nonideal factors, such as the restricted bandwidth of the output current loop, the time interval made by the signal detecting circuit, along with the reference command current generation process,

will deteriorate the compensation effect. Second, H-bridge cascaded STATCOM is a difficult system with many H-bridge cells in each phase, so the dc capacitor voltage imbalance concern, which is affected by different active power losses among the cells, different switching patterns for different cells, parameter deviations of active and passive components inside cells will influence the reliability of the system and even lead to the breakdown of the system. Henceforth, lots of researches have focused on seeking the solutions to these problems.

## 2. EXISTING SYSTEM

H-Bridge is connected in between the source and destination. Inside the H-Bridge inverter is connected in star format using MOSFET devices. Gate Pulse for these devices are provided from the P controller. The controller is designed to perform the controlled operation with the help of Reactive current reference algorithm. These control units perform with reference to only Current values. The DC capacitor voltage is also considered for the Controlling operation. Current from the line source is measured and then by using the current reference algorithm p controller produce the pulse. This pulse is used by h bridge inverter for the reactive power compensation.

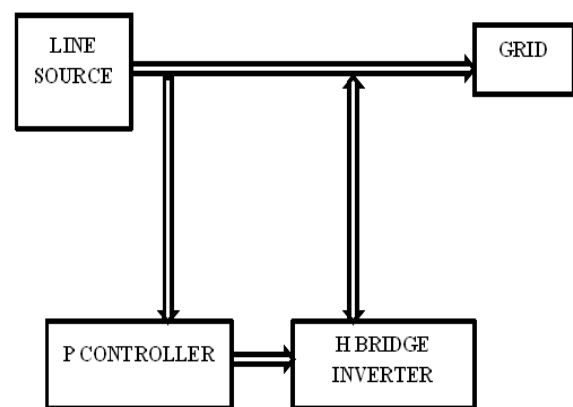

Figure 1. Existing Block Diagram

## 3. PROPOSED SYSTEM

The proposed block diagram is with H6 inverter inside the STATCOM. The STATCOM is connected in between the source and destination. Inside this STATCOM the H6 inverter is connected in star configuration using MOSFET devices. Gate Pulse for these devices are provided from the controller Pulse generator. The PR controller is designed to perform the controlled operation with the help of overall voltage control, Passivity-Based, Individual balancing control and Cluster control. These control units perform with reference to Voltage and Current values.

The DC capacitor voltage is also considered for the Controlling operation. An artificial Fault is being injected for a particular time period which is also compensated by the STATCOM. Real and Reactive power compensation is done with fourier transformation.

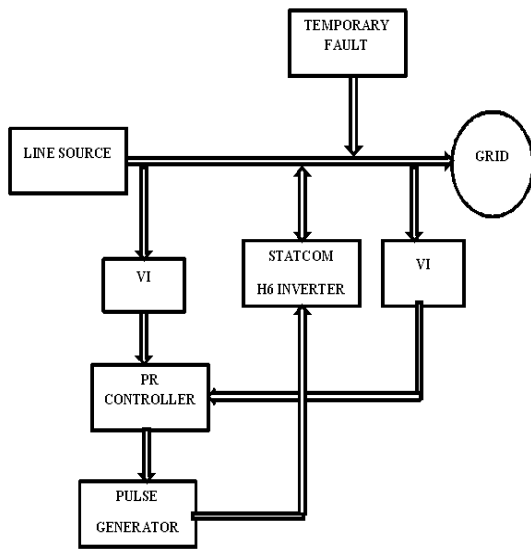

Figure 2. Proposed Block Diagram

#### 4. CONTROL BLOCK DIAGRAM

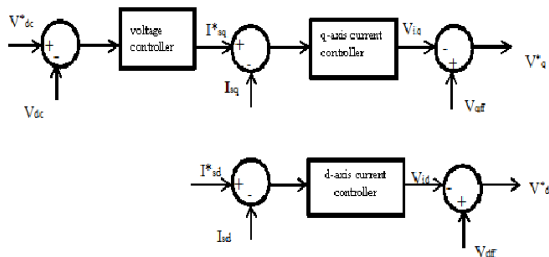

Figure 3. Control Block Diagram

##### A. Voltage Controller Design:

The design of voltage controller is done by pole zero cancellation method. The transfer function for the PI controller is given by,

$$\left( K_P + \frac{K_I}{s} \right) \quad (1)$$

By solving the equations we get,

$$\frac{K_P}{K_I} = R_0 C_0 \quad (2)$$

The transfer function for voltage control is given below,

$$\frac{V_{dc}}{V_{dc}^*} = \frac{1}{\frac{s}{K_I R_0} + 1} \quad (3)$$

The voltage control loop is given by

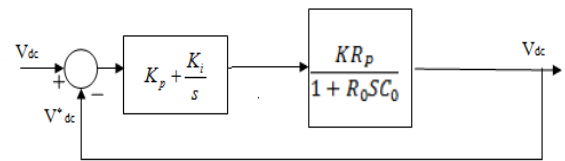

Figure 4. Voltage Control Loop

##### b. Current Controller Design:

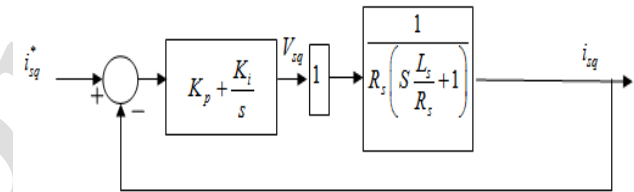

Figure 5. Current Control Loop

Current Controller designed with pole zero cancellation as,

$$\frac{K_P}{K_I} = \frac{L_S}{R_S} \quad (4)$$

Close loop transfer function is given by,

$$\frac{I_{sd}}{I^*_{sd}} = \frac{1}{1 + s \frac{R_S}{K_I}} \quad (5)$$

#### 5. VOLTAGE SOURCE INVERTER CONTROL

In order to manage three phase voltage source inverters (VSI), there are two control approach: current control and voltage control. The voltage controlled VSI use the phase angle connecting the inverter output voltage and the grid voltage to manage the power flow. The current controlled voltage source inverter, the active and reactive components of the current add into the grid are controlled by means of pulse width modulation (PWM) techniques. A current controller is less susceptible to voltage phase shifts and to alteration in the grid voltage. Moreover, it is quicker in response. On the other hand, the voltage control is susceptible to little phase errors and large harmonic currents may arise if the grid voltage is distorted. The current controller of

three phases VSI acting as necessary part in controlling grid connected inverters.

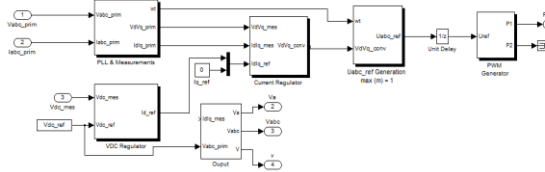

Figure 6. VSC Controller

Accordingly, the quality of the relevant current controller mostly influences the presentation of the inverter system. Many control mechanisms have been planned to control the inverter output current that is injected into the utility grid. Among these control mechanisms, three major types of current controller have evolved: hysteresis controller, predictive controller and linear proportional integral (PI) controller. Predictive controller has a very good steady state performance and provides a good dynamic performance.

However, its performance is sensitive to system parameters. The hysteresis controller has a quick transient response, non-complex realization and an inherent current safety. However, the hysteresis controller has some disadvantages such as variable switching frequency and high current ripples. These sources reduce current quality and initiate difficulty in the output filter design.

### 7. SIMULATION DIAGRAM

H6 Bridge inverter is connected between source and grid for real and reactive power compensation. An artificial fault is injected temporarily very short time to verify that the reactive power is compensated.

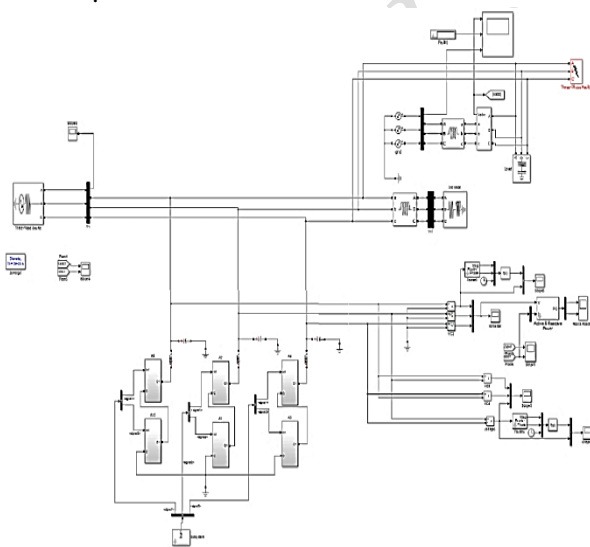

Figure 7. Simulation Diagram

### 8. SIMULATION RESULTS

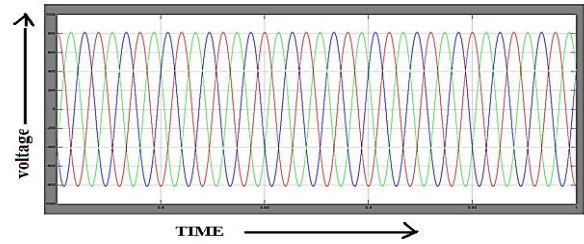

Figure 8. STATCOM Output Voltage

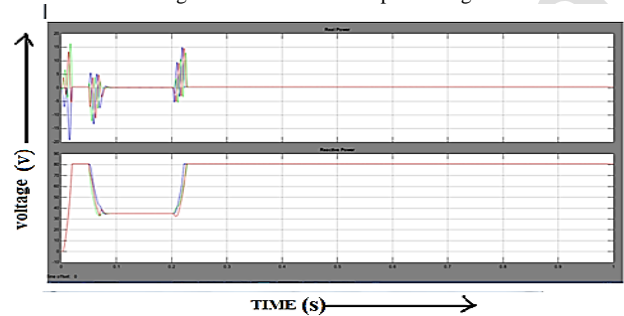

Figure 9. Real and Reactive Power Compensation

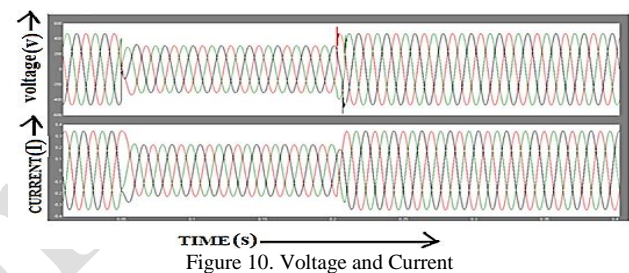

Figure 10. Voltage and Current

Above figure shows that current at initial condition is 0.4A and during the fault injection the current reduces to 0.2A.

### 6. CONCLUSION AND FUTURE WORK

This project has analyzed the fundamentals of STATCOM based on multilevel H6 converter with star configuration. And then, the actual H-6 cascaded STATCOM rated at 440V is constructed and the novel Passivity Based control, individual balancing control, cluster balancing control, overall voltage control methods are also proposed in detail. The experimental results have confirmed that the proposed methods are feasible and effective. In addition, the findings of this study can be extended to the control of any multilevel voltage source converter, especially those with H-6 cascaded structure. The real and reactive Power compensation has been obtained for the remodeled control unit. Power of 80W is obtained after the fault time period of 0.1s. The power obtained is the same as that of the input power. 0.4A of current is obtained after the fault injection where the current reduces to 0.2A. Due to the compensation techniques, input current of 0.4A is obtained. 400V is obtained as the final output voltage. This provides a high efficient output while comparing with the existing H-Bridge inverter. The results of simulation tests are performed to evaluate the system performance using MATLAB SIMULINK. In the future, individual phase current control can be implemented which enables star-connected STATCOMs to adapt to



unbalanced conditions without the essential for any power balancing algorithms.

#### REFERENCES

- [1] B. Singh and S. R. Arya, "Adaptive theory-based improved linear sinusoidal tracer control algorithm for DSTATCOM," *IEEE Trans. Power Electron.*, vol. 28, no. 8, pp. 3768–3778, Aug. 2013.
- [2] V. Spitsa, A. Alexandrovitz, and E. Zeheb, "Design of a robust state feedback controller for a STATCOM using a zero set concept," *IEEE Trans. Power Del.*, vol. 25, no. 1, pp. 456–467, Jan. 2010.
- [3] Y. Shi, B. Liu, and S. Duan, "Eliminating DC current injection in current transformer-sensed STATCOMs," *IEEE Trans. Power Electron.*, vol. 28, no. 8, pp. 3760–3767, Aug. 2013.
- [4] K. Sano and M. Takasaki, "A transformerless D-STATCOM based a multivoltage cascade converter requiring no DC sources," *IEEE Trans. Power Electron.*, vol. 27, no. 6, pp. 2783–2795, Jun. 2012.
- [5] B. S. Chen and Y. Y. Hsu, "A minimal harmonic controller for a STATCOM," *IEEE Trans. Ind. Electron.*, vol. 55, no. 5, pp. 655–664, Feb. 2008.
- [6] A. Luo, C. Tang, Z. Shuai, J. Tang, X. Y. Xu, and D. Chen, "Fuzzy-PI based direct-output-voltage control strategy for the STATCOM used in utility distribution systems," *IEEE Trans. Ind. Electron.*, vol. 56, no. 7, pp. 2401–2411, Jul. 2009.
- [7] C. H. Liu and Y. Y. Hsu, "Design of a self-tuning PI controller for a STATCOM using particle swarm optimization," *IEEE Trans. Ind. Electron.*, vol. 57, no. 2, pp. 702–715, Feb. 2010.
- [8] K. Sundaraju and A. N. Kumar, "Cascaded control of multilevel converter based STATCOM for power system compensation of load variation," *Int. J. Comput. Appl.*, vol. 40, no. 5, pp. 30–35, Feb. 2012.